



Maumee High School

2017/2018

1147 Saco St.

Maumee, OH. 43537

High School Phone Number.....(419) 893-8778

High School Fax Number.....(419) 893-5621

Maumee City Schools Website:

http://www.maumee.k12.oh.us/schools/maumee_high_school/index.php

Follow MHS on Twitter

@maumeehs

Property of: _____

Address: _____

Phone #: _____

The information in this book was the best available at press time. Watch for additional information and changes.



an sdi innovations company

No part of this publication may be reproduced, stored in a retrieval system, or transmitted in any form, without getting prior written permission of the publisher.

©2017. SDI Innovations. All Rights Reserved.

2880 U.S. Hwy. 231 S. • Lafayette, IN 47909 • 765.471.8883
<http://www.schooldatebooks.com> • sdi@schooldatebooks.com

TABLE OF CONTENTS

Message From the Principal.....	4	Graduation Recognitions.....	14
Statement of Philosophy.....	4	Graduation Ceremony.....	15
Maumee City Schools Mission Statement.....	4	Honor Roll.....	16
Maumee City Schools		Honors Program.....	16
Excellence in Action		CC+ (College Credit Plus) Program.....	16
2017-2018 MHS Master Calendar.....	5	Special Education.....	16
MHS Contact Information.....	7	State & Advanced Placement Testing.....	16
Other Maumee City Schools Contacts.....	7	Weighted Grading System.....	17
Bell Schedule for Classes.....	8	Courses to Receive Weighted A (5 Point) and	
General Information.....	9	B (4 Point) Grades.....	17
Accidents or Illness - In-School/Emergency		Attendance Policy.....	17
Medical Authorization.....	9	Notification & Loss of Academic Credit.....	19
Change of Address, Phone, Email,		Excused Late Arrivals and Early Dismissals	
Emergency Authorization.....	9	From School.....	19
Civil Rights Statement.....	9	Attendance and Activities.....	19
Deliveries to School for Students.....	9	Family Vacations During School Dates.....	19
Driver's Education.....	9	Truancy.....	20
Elevator Usage.....	9	Disciplinary Code of Conduct.....	20
Exterior Doors.....	9	A Violation of Any Rule May Result in	
Field Trips.....	10	Disciplinary Action, Including Removal,	
Food and Beverages.....	10	Suspension, or Expulsion.....	22
Hall Passes.....	10	Academic Honesty.....	23
Homework While Absent.....	10	(Board Policy 5517).....	24
Late Arrival / Early Release (Scheduled).....	10	Other Unlawful Harassment.....	25
Library.....	10	Reports and Complaints of Harassing Conduct...	25
Link.....	10	Privacy/Confidentiality.....	26
Lockers.....	10	Sanctions and Monitoring.....	26
Lost and Found.....	11	Education and Training.....	26
Office Aides.....	11	Bullying and Other Forms of	
Parent Portal - Electronic Gradebook.....	11	Aggressive Behavior.....	27
Posters.....	11	Complaints.....	27
School Board Policy on Drug-Free Schools.....	11	Privacy/Confidentiality.....	28
Residency/Enrollment.....	11	Reporting Requirement.....	28
Student Fees and Fines.....	11	Notification.....	28
Student Records (FERPA).....	12	Education and Training.....	29
Student Transcripts.....	12	Immunity.....	29
Student Valuables.....	12	Positive Behavior Intervention Supports.....	29
Surveillance Cameras.....	12	Teacher Assigned Detention System.....	29
Textbook Care.....	12	Denial of School Privileges.....	29
Use of School Equipment and Facilities.....	12	In-School Reassignment Program (I.R.P).....	30
Visitors.....	12	Saturday School Detention.....	30
Withdraw/Transfer From School.....	12	Out of School Suspension.....	30
Work Permits.....	12	Expulsion.....	30
Academics.....	13	Participation in School-Related Activities	
17-18 Academic Awards Nights.....	13	While Serving In-School Resassignments,	
Courses and Curriculum.....	13	Suspension or Expulsion.....	30
Final Exams and Culminating Projects.....	13	Students as Adults.....	31
Exam Waivers - Types and How to Earn Them...	13	Drug Abuse and Alcohol Guidelines.....	31
Exam Waiver - Removal.....	14	Maumee City Schools Student Dress Policy.....	31
Graduation Requirements - Credits		General Guidelines & Restrictions.....	31
and Assessments.....	14	Guidance Services.....	32
Credit Requirements.....	14	College Admissions Counselors' Visits.....	33
State Assessment Requirement.....	14	College Information.....	33
Graduation Requirements - Honors Diploma.....	14	College Visitations/Job Shadowing.....	33

Educational Options	33	Cell Phones, Ipods, MP 3 Players, CD Players, and Wireless Communication Devices	42
Guidance Website	33	Sexting.....	42
Military Information	34	Photographs/Video/Voice Recordings	43
Summer School.....	34	Bus Transportation	43
Penta Career Center	34	Student Responsibilities	43
On-Line Grading Program	35	Forbidden Cargo.....	43
Senior Class Information	36	Student Driving.....	43
Commencement	36	Co-Curricular Drug Testing Policy	44
Early Completion of High School.....	36	(Board Policy 5530.01).....	44
Early Graduate Expectations	37	Student Activities	44
Breakfast and Lunch Program.....	37	Assemblies	44
Lunch Period Regulations	37	Good Sportsmanship.....	45
Breakfast Program.....	37	Use of Medications.....	45
Fire Drills and Tornado Drills	38	Interscholastic Sports	47
Lockdown Drills / A.L.I.C.E Drills	38	Music and Drama	47
Fire/Tornado Warning/Lockdown Event.....	38	Clubs and Activities	47
Search and Seizure	38	Maumee Athletics	47
(Board Policy 5771)	38	Athletic Eligibility.....	48
Student Expression	39	Maumee City Schools Athletic/ Extracurricular/Co-Curricular Activity Code of Conduct.....	48
(Board Policy 5723).....	39	Prohibited Conduct.....	49
Procedures	39	Traditions	55
Time, Place, and Manner of Distribution or Display.....	40	Purple and Gold.....	55
School-Sponsored Publications and Productions	40	The Panther.....	55
General Prohibitions	41	Alma Mater	55
Responsible Use Policy for Technology and Network Use	41	Fight Song	55
(Board Policy 5136).....	41		



MESSAGE FROM THE PRINCIPAL

Dear Panthers and Panther Parents,

As we approach the beginning of a new school year, I would like to take this opportunity to welcome all of you. For many, it is a greeting extended to old friends; to others, it is an introduction and an invitation. To all it constitutes a pledge of continued efforts to provide the best possible education for our young men and women.

Maumee High School's reputation and success rest, in large measure, on parental concern and involvement. We seek to afford each student an education commensurate with his or her abilities, relevant to the country's needs, and challenging to a degree that will prompt a love of learning. This is no easy task. We need your cooperation and understanding if this year is to provide a profitable and satisfying experience for your child. Our school, from its foundation, has stressed academic excellence. In this there is no compromise or change.

Maumee High School can take pride in its highly qualified and dedicated faculty. These educators welcome your concerns, and they view education as a partnership between home and school. Over the years, the spirit and tradition that is our school have played a key role in shaping the educational experience. Each class profits from the example of those who have gone before them. Ours has been a tradition of students committed to the proposition that the privilege of coming to school carries with it the obligation to do the best they can. These are important years, and it is reassuring to work with young people who see a challenge in their potential-to become the best they can.

In an effort to improve the communication between the home and the school, we ask that you take the time to read this handbook, discuss it with your son or daughter, and refer to it at various times of the year. We trust that your experience with our school will enhance your faith in public education and that you will find in this school an education for your children that is worthy of your love and concern for them.

Sincerely,

Matt Dick, Principal

STATEMENT OF PHILOSOPHY

The Maumee City Schools are dedicated to the perpetuation and improvement of our democratic society by means of the fullest possible development of the knowledge, skills, habits, understanding, attitudes, and character traits essential for rich, personal living; the sound choice of and effective participation in a vocation; satisfying human relationships; and responsible, contributing citizenship. In order to accomplish these goals successfully, schools must reflect and be responsive to the needs of the community.

In the practical application of this philosophy, opportunities shall be provided each individual to develop:

- A. moral and ethical values, which include respect for self, for others, for property, and for the laws of our society
- B. physical and emotional health
- C. an appreciation for his/her role in the family, in the school, and in the community
- D. knowledge and respect of his/her natural environment
- E. economic competence as a consumer
- F. knowledge and appreciation of educational and vocational choices, which are available to each individual
- G. knowledge and appreciation of the arts
- H. knowledge and skill to allow for wise use of leisure time
- I. zeal for continuous learning and self-improvement
- J. the ability to make reliable judgments based on analytical and creative thinking
- K. love of country and effective participation in the democratic process

MAUMEE CITY SCHOOLS MISSION STATEMENT

Our Mission

The mission of the Maumee City School District is to be a welcoming school community with academic standards designed to ensure all students are confident, prepared, and empowered to be life-long learners and socially responsible citizens with the ability to compete and succeed in an ever-changing global society.

Maumee is distinguished by:

- Rigorous and relevant academics at all grade levels
- Safe, secure and nurturing learning environment
- Focus on building strong, meaningful relationships
- Graduates well prepared for success in college and career

MAUMEE CITY SCHOOLS EXCELLENCE IN ACTION 2017-2018 MHS MASTER CALENDAR

Wednesday	August	16	First Day of School 9th grade students and LINK leaders
Thursday		17	First Day of School for all MHS students
Friday		18	School Pictures
Wednesday		23	MHS Open House (7 pm)
Monday	September	4	Labor Day – No School
Wednesday		13	Staff Professional Development Day – No School
Monday		18	Financial Aid Night
Thursday		28	School Picture Retake/Makeup during lunches NHS Breakfast
Saturday	October	7	Homecoming Dance
Saturday		14	Music in Motion (Kazmaier Stadium)
Wednesday		11	Staff Professional Development Day – No School
Thursday (Evening – MHS)		12	Parent-Teacher Conferences & Parent College Info Night
Friday		20	Senior Panoramic (8 am in MHS GYM)
Tuesday		24	German Classes Oktoberfest
Wednesday		25	PSAT (all Sophomores & Select Juniors)
Thursday		26	Spirit Bonfire
Friday		27	Field Day/Battle for the Bell
Thursday	November	2	MHS Fall Choir Concert Explore Penta Day (10th grade)
Monday		6	Cocoa and Cram (exam preparation) (3 pm)
Tuesday		7	Inservice Day (Election Day) - No School
Wednesday		8	1st trimester exams periods 1 & 2
Thursday		9	1st trimester exams periods 3-5 & End of 1st Trimester
Friday-Sunday		10-12	Senior Class Trip to NYC
Friday		10	Teacher Records Day MHS - No School
Monday		13	2nd Trimester Begins
Friday-Sunday		17-19	Fall Play
Monday		20	College Credit Plus Night (7pm)
Wednesday-Friday		22-24	Thanksgiving Break- No School
Thursday	December	14	Orchestra (6 pm) & Band (8 pm) Holiday Concert
Thursday		21	Choir Holiday Concert (7 pm)
Friday		22	Last Day of Class before Winter Break
Wednesday	January	3	Classes Resume
Thursday		11	Parent-Teacher Conferences (evening) - MHS
Monday		15	Martin Luther King Day – No School
Wednesday		31	8th Grade Open House (7 pm)
Thursday	February	8	Staff Professional Development Day – No School
Monday		12	3rd Annual Science Night (6 pm)
Thursday		15	MHS Choir Coffee House (7 pm)
Monday		19	Presidents Day - No School

Wednesday		21	2nd trimester exams periods 1 & 2
Thursday		22	2nd trimester exams periods 3-5 & End of 2nd Trimester Band and Orchestra Winter Concert (7 pm)
Friday		23	Teacher Records Day MHS - No School
Monday		26	3rd Trimester Begins
Wednesday	March	7	11th Grade Required SAT Testing College Preview Night (7 pm – Owens Community College)
Friday-Sunday		16-18	Spring Musical
Thursday		29	Last Day of Class before Spring Break
Monday	April	9	Classes Resume
Thursday		19	NHS Induction Ceremony (7 pm)
Tuesday & Wednesday		24-25	EOC Testing (English 1 and 2)
Saturday		28	Prom
Monday	May	1	EOC Testing (Biology)
Tuesday		2	EOC Testing (Algebra & Geometry)
Wednesday		3	EOC Testing (US History, US Government)
Monday	May	7	Academic Awards Night (7 pm in PAC)
Wednesday		9	Music and Arts Festival
Monday		14	Scholarship Match Night (7 pm at St. Luke's Hospital)
Wednesday		16	Senior Last Supper (6 pm)
Thursday		17	Spring Choir Concert (7 pm)
Friday		18	Career Day
Monday		21	3rd Trimester Exams Periods 3-5 (Grade 12 ONLY)
Tuesday		22	3rd Trimester Exams Periods 1 & 2 (Grades 9-12) Graduation Practice @ 12:30 pm (Stranahan Theater)
Wednesday		23	3rd Trimester Exams Periods 3-5 (Grades 9-11 ONLY)
Thursday		24	Staff Work Day LINK Development Day Baccalaureate @ 7 pm
Saturday		26	Graduation @ 12 pm (Stranahan Theater)

MHS CONTACT INFORMATION

419-893-8778

Principal	Matt Dick	matt dick@maumeeek12.org
Assistant Principal	Scott Perrotte	sperrotte@maumeeek12.org
Athletic & Activities Director	Matt Szyndler	mszyndler@maumeeek12.org
Athletic/Activities Secretary	Michelle Greenawalt	mgreenawalt@maumeeek12.org
Attendance Secretary	Chelsea Kolacki	ckolacki@maumeeek12.org
Bookkeeper	Michelle Greenawalt	mgreenawalt@maumeeek12.org
Credit Recovery Center	Karen Brebberman	kbrebberman@maumeeek12.org
Dean of Students	Gretchen Brown	gbrown@maumeeek12.org
Flex Credit / CC+	Donna Massengill	dmassengill@maumeeek12.org
Guidance Secretary	Michelle Leasor	mleasor@maumeeek12.org
Guidance Counselors		
Last Names A - F	Justin Fults	jfults@maumeeek12.org
Last Names G - M	Courtney Gilts	cgilts@maumeeek12.org
Last Names N - Z	Donna Massengill	dmassengill@maumeeek12.org
Library	Karen Brebberman	kbrebberman@maumeeek12.org
Nurse	Jane Fender	jfender@maumeeek12.org
Parking Tags	Gretchen Brown	gbrown@maumeeek12.org
Principal's Secretary	Kristy Kolacki	kkolacki@maumeeek12.org
SAIL Counselor	Andrea Loch	aloch@maumeeek12.org
School Resource Officer	Ofc. Scott Russell	srussell@maumeeek12.org
Special Education (HS)	Cori Wagner	cwagner@maumeeek12.org

OTHER MAUMEE CITY SCHOOLS CONTACTS

Transportation & Food Services	Mary Bottoni	419-893-1392	mbottoni@maumeeek12.org
New Student Enrollment	Nicole Hinsey	419-893-3200	nhinsey@maumeeek12.org

CENTRAL ADMINISTRATIVE OFFICES (419) 893-3200

Dr. Todd Cramer, Superintendent
 Steven Lee, Assistant Superintendent
 Michelle Shafer, Curriculum Director
 Tricia Samuel, Director of Special Education
 Jason Dugan, Technology Coordinator
 Paul Brotzki, Treasurer

BELL SCHEDULE FOR CLASSES

REGULAR DAILY SCHEDULE

1. 7:43 – 8:53
2. 8:58 – 10:10
3. 10:15 – 11:25
- 4a. **11:30 – 12:00**; 12:05 – 1:15
- 4b. 11:30 – 12:00; **12:05 – 12:30**; 12:35 – 1:15
- 4c. 11:30 – 12:40; **12:45 – 1:15**
5. 1:20 – 2:30

TWO HOUR DELAY SCHEDULE

1. 9:43 – 10:27
2. 10:32 – 11:18
- 4a. **11:23 – 11:48**; 11:53 – 12:53
- 4b. 11:23 – 11:48; **11:53 – 12:18**; 12:23 – 12:53
- 4c. 11:23 – 12:23; **12:28 – 12:53**
3. 12:58 – 1:42
5. 1:47 – 2:30

HOMEROOM SCHEDULE

1. 7:43 – 8:47
- Homeroom 8:52 – 9:17
2. 9:22 – 10:28
3. 10:33 – 11:37
- 4a. **11:42 – 12:12**; 12:17 – 1:22
- 4b. 11:42 – 12:12; **12:17 – 12:42**; 12:47 -1:22
- 4c. 11:42 – 12:47; **12:52 – 1:22**
5. 1:27 – 2:30

EXAM SCHEDULE

1st Day

1. [1st period exam] 7:43 – 9:00
2. [2nd period exam] 9:07 – 10:24
3. 10:29 – 11:34
- 4a. **11:39 – 12:09**; 12:14 – 1:19
- 4b. 11:39 – 12:09; **12:14 – 12:44**; 12:49 – 1:19
- 4c. 11:39 – 12:44; **12:49 – 1:19**
5. 1:24 – 2:30

2nd Day

1. [3rd period exam] 7:43 – 9:00
2. [4th period exam] 9:07 – 10:24
3. [5th period exam] 10:31 – 11:48
- Exam Make-Up 12:00 – 1:17

10 am OPTIONAL START (EOC Testing)

- 1st 10:00 - 10:43
- 2nd 10:47 - 11:30
- 4a 11:34 - 11:59
- 4b 12:03 - 12:28
- 4c 12:32 - 12:57
- 3rd 1:01 - 1:44
- 5th 1:48 - 2:30

11 am OPTIONAL START (EOC Testing)

- 1st 11:00 - 11:28
- 4a 11:32 - 11:5
- 4b 12:01 - 12:26
- 4c 12:30 - 12:55
- 2nd 12:59 - 1:27
- 3rd 1:31 - 1:58
- 5th 2:02 - 2:30

SCHOOL CLOSING FOR INCLEMENT WEATHER

If the Maumee City Schools are to be closed due to inclement weather, this information can be heard by listening to one of Toledo's radio stations. The school administration will make every effort to have this information to the radio stations by 7:00 am. A message will also be sent to you using the instant alert system. Please do not call the school.

The front doors at Maumee High School will open at 7:00 am for student access. Students will not be supervised prior to 7:00 am. Students who are not under the supervision of a teacher, club advisor or coach are expected to leave the building by 4:00 pm.

GENERAL INFORMATION

ACCIDENTS OR ILLNESS - IN-SCHOOL/EMERGENCY MEDICAL AUTHORIZATION

All parents are required to complete Emergency Medical Information for their student at the beginning of each school year. Parents will be called at the phone numbers listed when their student becomes ill at school. Parents will also be called regarding minor accidents and injuries. Severely ill or injured students who require immediate medical care will be treated according to the instructions the parent provides. Parents would be notified as soon as possible in such cases. Students will ONLY be released to those emergency contacts listed unless the parent confirms that someone other than that listed on the emergency contacts list is approved for a one-time release and the ID of this person can be verified by school officials. If there is any question as to the identity of a person requesting to pick up a student and the parent cannot be contacted, the student will not be released.

CHANGE OF ADDRESS, PHONE, EMAIL, EMERGENCY AUTHORIZATION

Parents are responsible for keeping all student demographic records up-to-date through the PowerSchool portal. The information stored in this system will be the primary source of contact information.

CIVIL RIGHTS STATEMENT

The Maumee City School District, in accordance with guidelines established by Federal and State laws, offers educational activities, employment, programs and services without regard to race, color, national origin, sex, religion, handicap, or age. Anyone who has concerns or questions about possible discrimination should contact Director of Pupil Personnel Services, Title VI, Title IX and Section 504 Coordinator, at 716 Askin St. Maumee, Ohio 43537 (419-893-3200) for information or grievance forms. The Office of Civil rights, Region V, 55 Erieview Place, Room 222, Cleveland, Ohio 44114, (216-522-4970) may also be contacted.

In Case of Discrimination:

The grievance procedures begin with the student presenting, in writing, his or her alleged grievance to the building principal or Title VI, Title IX, Section 504 compliance officer. A copy of the complete grievance procedure is available, upon request, from the Director of Pupil Personnel Services located in the Maumee City School District Board Office. The Maumee City School District is continuing to comply with Title VI, Title IX, and Section 504 regulations.

DELIVERIES TO SCHOOL FOR STUDENTS

Any emergency item(s) that need to be delivered to a student, once the school day has begun, should be brought to the main office. The office staff will send for the student to receive the item(s). All flowers, candy, balloons, etc. will be kept in the front office and then picked up at the end of the school day. Students are not permitted to receive fast-food delivery during the school day and during lunch periods.

DRIVER'S EDUCATION

Student's will complete driver's education through a private driving school. Remember, Ohio law requires anyone under age 18 to complete a valid driver's education course prior to receiving an Ohio operator's license.

ELEVATOR USAGE

Only students who have permission from the principal may use the elevator.

EXTERIOR DOORS

Exterior doors will be locked at 7:43 am and the only entry to the school building thereafter will be through the front office. Exterior doors may not be propped open during the school day.

FIELD TRIPS

Field trips are academic activities that are held off of school grounds. There are also other trips that are part of Maumee High School's co-curricular and extra-curricular program. No minor student may participate in any school-sponsored trip without parental consent and current emergency medical contact information in PowerSchool. Medications normally administered at school will be administered while on field trips. The Student Code of Conduct and attendance policy apply to all field trips. While the district encourages students to participate in field trips, alternative assignments will be provided for any student whose parent does not give permission for the student to attend. Students who violate the Code of Conduct will be subject to school discipline and/or may have field trip privileges revoked.

FOOD AND BEVERAGES

Food and beverages are permitted in the cafeteria and in classrooms, with permission of the individual teacher, where the food and beverage is part of the daily curriculum. Food and beverages are not permitted in the Performing Arts Center at any time. **Fast food deliveries to the lunch room are not permitted.**

HALL PASSES

Hall passes are controlled by individual teachers and are a privilege, not a right. To use a hall pass, the student must sign the log noting time out, time in, and destination. Hall passes from the office may be marked as "immediate" or "when convenient" (at teacher's convenience). Students who are in the hall for an excessive period of time, as determined by the teacher, may be disciplined or may have their hall pass privilege revoked.

HOMEWORK WHILE ABSENT

Students are responsible for talking to individual teachers about making up assignments missed while absent. Prolonged absences should be made known to the student's guidance counselor who can gather assignments or decide if other options should be pursued. There are time limits in which missing homework due to absence will no longer be received for credit.

LATE ARRIVAL / EARLY RELEASE (SCHEDULED)

Students who have a scheduled late arrival to or early release from school need to have their transportation arranged such that they are not at MHS during times in which there is no scheduled class. There is no "study hall" available for these students. When you and your parents choose to exercise a late arrival or early release you are also agreeing to provide transportation that removes you from school grounds during these times.

LIBRARY

The students' ID card also serves as their library card and students may borrow books, magazines, and pamphlets. In addition to the books, the library has computers available with access to the Internet, numerous on-line databases, and specialized programs for specific classes. Maumee High School library also has a web page that can be accessed through the high school web page. The web page has many databases that students may access at home. All students receive a password list, which is needed to access these databases at home. The librarian is here to help you. Don't hesitate to ask for assistance.

LINK

All freshmen and students new to Maumee High School will be involved in the LINK program, a comprehensive program that will assist students with the transition into Maumee High School. The LINK program consists of student mentors, faculty advisors, and academic counselors who work together to foster a positive experience for all students new to our school. Student mentors are expected to be positive role models and trusted guides for the new students.

LOCKERS

Every student will be assigned a locker. Students must use the locker assigned to them unless they make other arrangements with the Assistant Principal. Students may **NOT** share lockers. Students found to be sharing lockers may be subject to the demerit system. Only locks made especially for the school are permitted on lockers. Students are not required to place a lock on their locker, however all lockers without an approved lock will be secured. The school accepts no responsibility for the contents of lockers. The right to open and inspect lockers with or without the student's consent is held by the school. A student is to be held responsible for any school property found in his locker. Writing on the lockers is strictly prohibited. Lockers will also be available for physical education classes and athletic teams. Students are reminded to keep all physical education class lockers locked and secured at all times. Students who have a problem with their locker are asked to see the Assistant Principal.

LOST AND FOUND

Lost and found items may be retrieved from the office. Every trimester the unclaimed lost and found items will be disposed of.

OFFICE AIDES

Only juniors and seniors may apply to be office aides. Applications will be filled out during registration. There are only 2 aides per period of the day. The office staff has complete discretion on choosing office aides and may choose some students from the applicant pool more than once and others not at all. Being an office aide is a privilege, not a right, and the privilege can be revoked at any time for any reason.

PARENT PORTAL – ELECTRONIC GRADEBOOK

This feature of the Maumee High School electronic gradebook allows parents to keep track of student progress and communicate directly with classroom teachers. **Account information (login/password) will be given to students via homeroom. The MHS guidance secretary can provide and reset parent passwords.**

POSTERS

Any posters fastened to the walls must be attached with masking tape, and then only to the ceramic tile. **Nothing is to be attached to the painted area of the wall.** All posters must be approved by the administration.

SCHOOL BOARD POLICY ON DRUG-FREE SCHOOLS

In accordance with Federal law, the Board of Education prohibits the use, possession, concealment, or distribution of drugs by students on school grounds, in school, or school-approved vehicles, or at any school-related event. Drugs include any alcoholic beverage, anabolic steroid, dangerous controlled substance as defined by State Statute, or substances that could be considered a “look-a-like” controlled substance. Compliance with this policy is mandatory for all students. Any student who violates this policy will be subject to disciplinary action, in accordance with due process and as specified in the student handbooks, up to and including expulsion from school. When required by State law, the District will also notify law enforcement officials. The District is concerned about any student who is a victim of alcohol or drug abuse and will facilitate the process by which he/she receives help through programs and services available in the community. Students and their parents should contact the school principal or counseling office whenever such help is needed.

RESIDENCY/ENROLLMENT

Only student residents or court-placed non-residents may attend Maumee High School tuition free. The Maumee City Schools are not an “open enrollment” district and do not accept students from out-of-district. Parent(s)/Guardian(s) have the responsibility to establish and maintain a permanent residence and may be asked to prove residency at any point during the year. Parent(s)/Guardian(s) who cannot prove residency to the satisfaction of standard established by the Maumee City Schools board will be required to withdraw their child and pay tuition restitution. Proof of residency is the responsibility of the parent/guardian and the district may require re-verification at any time of the year and/or multiple times in the year.

SCHOOL INFORMATION

Maumee High School makes extensive use of the communication tools provided in the Parent Portal. Emails about upcoming events are sent out regularly. This email system is our primary communication tool. Parents need to make sure that their current email address is entered into the Parent Portal and that their spam filter is not intercepting school messages.

STUDENT FEES AND FINES

Most courses will have School Board approved expenses involved. Be sure that you are aware of what the financial obligations are involved in the course. All fees and fines must be paid before the student may participate in the graduation ceremony, receive a diploma, or receive a requested transcript.

STUDENT PICTURES / ID'S

All students can have an individual portrait picture taken at school for a minimal cost. Underclassmen (grades 9-11) have their picture taken in the first weeks of school. Students who wish to purchase additional pictures can make arrangements at the time the picture is taken with the photographer. If for some reason the picture results are not satisfactory, picture retakes are scheduled at a later date.

Seniors are generally contacted by a local photography agency to schedule an appointment to take a formal senior portrait. This arrangement is made by a photographer working in conjunction with the school yearbook. The photographer appointments are normally scheduled in the summer months. Students are under no obligation to engage the school-designated photographer. Be advised, however, that this photographer does provide the pictures to be included in the senior section of the yearbook. **Student ID's are required for attendance to many MHS functions including dances, lock-in, etc.**

STUDENT RECORDS (FERPA)

Student records will only be released in accordance with Maumee City Schools District Policy 8330.

STUDENT TRANSCRIPTS

May be requested from the guidance secretary.

STUDENT VALUABLES

Students should not bring items of value to school. Items such as jewelry, expensive clothing, electronic equipment, and the like are tempting targets for theft and extortion. Maumee City Schools will not be held liable for any loss or damage to personal valuables.

SURVEILLANCE CAMERAS

This facility is equipped with a surveillance system. This system may be used to monitor student conduct and to assist in disciplinary action. The system provides security to our facility, staff, and students.

TEXTBOOK CARE

Charges will be assessed for books receiving greater damage than could be expected from normal use and wear. The replacement price of a book will be charged for a lost book.

USE OF SCHOOL EQUIPMENT AND FACILITIES

Students must receive teacher permission before using any equipment or materials in the classroom. Students must seek permission from the principal prior to using any other school equipment or facility. Students are responsible for the proper use and protection of any equipment or facility they are permitted to use.

VISITORS

Visitors, particularly parents and former students, are welcome at Maumee High School (as consistent with school board policy 9150). Visitors must report to the office upon entering the school to sign in and obtain a pass. Any visitor found in the building without a pass or in an area that they were not authorized to visit, will be removed from the building. If a person wishes to confer with a member of the staff – teacher, counselor, or administrator – he/she should call for an appointment prior to coming to Maumee High School in order to schedule a mutually convenient meeting time. Visitors who arrive without an appointment may or may not be attended to depending on the daily course of events. Students may not bring visitors to school without office permission..

WITHDRAW/TRANSFER FROM SCHOOL

A student cannot be properly withdrawn from MHS to attend another school without completing these three steps:

- (1) Parent must fill out and sign a withdraw form at MHS
- (2) All of the student's fees and fines must be paid as well as the return of all books and classroom materials
- (3) The school in which the student is enrolling must send MHS a "records request" (can be faxed to 419-893-5621).

WORK PERMITS

Work permits are obtained through the high school office. Retention of this permit is contingent upon the student's academic progress and attendance at school.

ACADEMICS

The oldest chartered high school in the State of Ohio, Maumee High School is a public comprehensive/college preparatory high school with 6 basic programs to help individualize instruction: (1) College Preparatory, (2) Honors, Accelerated, Advanced Placement, and CC+ (3) Specific Learning Disabilities, (4) Multiple Handicaps, and (5) Vocational Programs through Penta Career Center.

Maumee High School has 61 certified faculty members with 19.7 average years of experience. In addition to a bachelor's degree in education, 56 staff members have a master's degrees and 3 have an educational specialist degree. 100% of the faculty is recognized as "highly qualified" in their content area.

17-18 ACADEMIC AWARDS NIGHTS

5/7/18 - Academic Awards Night - 7:00 pm in MHS Performing Arts Center: Students and parents of students receiving awards will be sent an invitation letter.

5/14/18 - Scholarship Match Night – 7:00 pm at St. Luke's Hospital Conference Room - Students and parents of students receiving awards will be sent an invitation letter.

COURSES AND CURRICULUM

Please consult the Maumee High School Curriculum Guide available in the Guidance Office and on the Guidance website.

CREDIT RECOVERY CENTER

While the trimester, by design, gives the students opportunity to quickly re-take failed courses, some students may find themselves jeopardizing their graduation date due to a lack of academic credit. The Credit Recovery Center, located in the High School library, allows students to take online courses via GradPoint to recover credit. Time in the CRC is scheduled in place of electives that the student may have registered to take. Students entering Maumee High School who are credit deficient for their age may be placed in the CRC for part of the school day until credit is recovered.

FINAL EXAMS AND CULMINATING PROJECTS

Every course at Maumee High School will have a Final Exam OR a Final Culminating Project at the end of each trimester and will count as 15-20% of the trimester grade. A *final exam* assesses the student's proficiency on learning standards or some special field of knowledge. A *final culminating project* requires a student to demonstrate a specific set of skills that were learned in the course (as determined by a grading rubric) and will require the student to make a formal presentation at the end of the course.

EXAM WAIVERS – TYPES AND HOW TO EARN THEM

When a student "waives" an exam, the course grade will be determined by the 80-85% of grades leading up to the final exam or final culminating project. An exam can only be waived if the student has a grade of 75% or higher prior to the exam. A student waiving a *final exam* will not be required to take the final exam. A student waiving a *final culminating project* will not have to formally present the project on the exam day. The following are the types of waivers that a student can earn:

EOC Exam Waiver – A student enrolled in the "Applications" level of an EOC course who scores a "3" or higher on the state graduation test will receive 1 exam waiver for the next school year for each "3" earned. A student enrolled in the "college preparatory", "accelerated", "honors", or "AP" level of an EOC course who scores a "4" or higher will receive 1 exam waiver for the next school year for each "4" earned. Any student who scores a "5" on an EOC will earn 2 exam waivers for the next school year for each "5" earned. These waivers can be used for any exam in any trimester in which the teacher permits waiver use provided the student has a grade of 75% or higher in the course prior to the exam. With permissions provided by the parent in the electronic registration portal, the student does not have to be in attendance during the period of the waived exam. A supervised study hall will be provided in the cafeteria during the exam periods for a student who is waiving an exam but lacks transportation to/from MHS. *EOC waivers are only awarded to students who take their EOC tests in the Maumee City Schools.*

AP Exam Waivers - Students who sign up for the spring trimester of one or more AP courses **and** take the AP tests that correspond to those classes may, at teacher discretion, be exempted from the final exam. With permissions provided by the parent in the electronic registration portal, the student does not have to be in attendance during the period of the waived exam. A supervised study hall will be provided in the cafeteria during the exam periods for a student who is waiving an exam but lacks transportation to/from MHS. Any student who takes the spring trimester of an AP course, but elects not to take the AP test, will be required to take a teacher-generated final exam.

Senior Exam Waivers - The senior class may choose to negotiate exam waivers as part of their end of the year senior privileges. These exams will have rules determined by the senior class office and building administration. With permissions provided by the parent in the electronic registration portal, the student does not have to be in attendance during the period of the waived exam.

EXAM WAIVER – REMOVAL

Any type of exam waiver above can be removed if one of the conditions below are met:

1. Student exceeds the limit of 2 unexcused tardies in a trimester.
2. Student exceeds the limit of 4 unconfirmed absences in the trimester.
3. Student receives demerits or disciplinary consequences for violating school rules.

GRADUATION REQUIREMENTS - GENERAL

The State Department of Education licenses Maumee High School as a high school of the first grade, the highest level in the State. A student must earn the specified units of credit in order to graduate from Maumee High School. A unit is 2 trimesters worth of work in a class which meets five days each week and has homework as a part of the course. At Maumee High School, you earn credit for each trimester of a course that you pass AND have acceptable attendance in. Students are responsible for keeping track of their credit and making sure that they are in line to graduate. Please contact your counselor should you have any questions or concerns about graduation requirements. In addition, Ohio Revised Code mandates that students participate in and achieve acceptable scores in graduation tests.

GRADUATION REQUIREMENTS – CREDITS AND ASSESSMENTS

CREDIT REQUIREMENTS

English (1,2,3,4 series)	4 units
Social Studies (must include 1 unit world hist, 1 unit US hist, 1 unit US Govt, and 0.5 unit Econ)	3.5 units
Science (must include 1 unit physical, 1 unit life, and 1 unit advanced)	3 units
Mathematics (must include algebra 1, geometry, and algebra 2)	4 units
Health/Physical Ed.	1 unit
Visual/Performing Arts	1 unit
Electives	6.5 units

Total Units Required

23 units

STATE ASSESSMENT REQUIREMENT

All students must earn a total of 18 points on the exit exams in English 1, English 2, biology, algebra, geometry, American history, and American Government and/or earn a “college ready” score on a standardized assessment of the state’s choosing and/or earn an approved industry credential.

GRADUATION REQUIREMENTS - HONORS DIPLOMA

To receive a State of Ohio Honors Diploma, students must meet 7 of the 8 following criteria:

- a) 4 units of English
- b) 4 units of math including Algebra I, Geometry, Algebra II, and another higher level mathematics course or a four-year sequence of courses that contain equivalent content.
- c) 4 units of Science including two units of Advanced Science
- d) 4 units of Social Studies
- e) 3 units of same Foreign Language or at least 2 units in two different languages.
- f) 1 unit of Fine Arts
- g) 3.5 Grade Point Average on a 4.0 scale
- h) 27 on the ACT or 1280 on the SAT (excluding scores from the writing sections).

GRADUATION RECOGNITIONS

Students will be recognized at the graduation ceremony for academics utilizing the Latin Honors System: *Summa Cum Laude* - Top 5% grade point average of students ranked on the 5.0 weighted scale for the graduating class and the attainment of a State of Ohio Honors Diploma. For rounding purposes, the ranked students will not be rounded up (for example, if 211 students graduate, ten (10) students will

be recognized in this category ($211 \times .05 = 10.55 =$ ten (10) students). Students will receive academic medallions and *Summa Cum Laude* will be stamped on the diploma. Class valedictorian and salutatorian will come from this category.

Magna Cum Laude – Top 6%-10% grade point average of students ranked on the 5.0 weighted scale for the graduating class and the attainment of a State of Ohio Honors Diploma. For rounding purposes, the ranked students will not be rounded up. Students will receive academic medallions and *Magna Cum Laude* will be stamped on the diploma.

Cum Laude - Top 11%-15% grade point average of students ranked on the 5.0 weighted scale for the graduating class and the attainment of a State of Ohio Honors Diploma. For rounding purposes, the ranked students will not be rounded up. Students will receive purple cords and *Cum Laude* will be stamped on the diploma.

Scholastic Honors - Top 16%-20% grade point average of students ranked on the 5.0 weighted scale for the graduating class and the attainment of a State of Ohio Honors Diploma. For rounding purposes, the ranked students will not be rounded up. Students will receive a scholastic honors certificate.

Additional recognitions at the graduation ceremony include:

- Latin Honors Medallions - Students who fulfill the graduation requirements for Latin Honors will be awarded medallions to wear at the graduation ceremony.
- Military - Students who have *signed a letter of commitment* to join the military after graduation will be recognized and wear military cords at the graduation ceremony.
- National Honors Society – Students who are currently members of NHS will wear gold cords and be recognized at the graduation ceremony.
- National Technical Honors Society Medallions – Penta Career Center students who have received National Technical Honors Society status will be encouraged to wear the medallion at the graduation ceremony and be recognized. PCC is in charge of distributing this medallion.
- Perfect Attendance – students with perfect senior year attendance (or multiple years including the senior year) will be recognized at graduation. Perfect attendance is defined as students who only have school-related absences (field trips, school events, or college visits) and no tardies on their attendance record. No other type of absence is permitted, excused or unexcused.

GRADUATION CEREMONY

The MHS graduation ceremony is a formal event. *The administration of Maumee High School has complete discretion over the MHS graduation ceremony, including who can or cannot participate and who can or cannot attend. In order to participate in the Maumee High School graduation ceremony, the student must meet graduation requirements, have paid all outstanding student fees and fines, and have served all assigned disciplinary consequences. If a disciplinary consequence occurs over or spans the graduation date, the student will not be able to participate in the event.*

Each senior will be given 10 admission tickets at graduation practice. If a student needs more tickets to the ceremony he/she will have to wait until after graduation practice and we will evenly distribute the remaining tickets between those who are requesting extras. Seniors **MUST** attend graduation practice in order to participate in the graduation ceremony unless excused by the administration.

Dress for graduation participants:

Ladies: Avoid dark colors or patterned dresses under the white graduation gown as these will “bleed through”. No tennis shoes, flip flops, excessively high heels, or boots are permitted. If the student wears unacceptable footwear, she will not be permitted to sit on the stage or cross the stage for the ceremony. Replacement shoes must be provided prior to the start of the ceremony or the student will not participate.

Gentlemen: Wear a button-down shirt and a tie. Brown or black slacks. Brown or black dress shoes. No tennis shoes, flip flops, sandals, or boots are permitted. If the student wears unacceptable footwear, he will not be permitted to sit on the stage or cross the stage for the ceremony. Replacement shoes must be provided prior to the start of the ceremony or the student will not participate.

Cords and Medallions: The only cords/medallions permitted to be worn at the graduation ceremony are those that have been distributed by the Maumee City Schools.

HONOR ROLL

An honor roll will be posted at the end of each trimester to recognize the academic efforts of Maumee High School students. Students on the "Recognition Honor Roll" will have a cumulative G.P.A. of 3.0 – 3.699. Students on the "Achievement Honor Roll" will have a cumulative GPA of 3.70 or higher. These lists will be released to the Maumee Mirror for publication and recognition.

HONORS PROGRAM

Honors program courses include all accelerated, honors, advanced placement (AP), and College Credit Plus. Program eligibility and course descriptions are available in the Honors Program Handbook.

CC+ (COLLEGE CREDIT PLUS) PROGRAM

Qualified Maumee High School students have the option of attending eligible two and four-year colleges and universities which offer both high school and college credit concurrently. These courses may occur on the college campus or at Maumee High School. Plans must be made well in advance. Interested students should contact a Maumee High School counselor for information. All fees are paid for the student by the State of Ohio. Most colleges require a high grade point average and/or a college ready score on a standardized test such as the ACT for admission to the program. Courses must be college level and not remedial. Summer classes are also available through this program. Detailed information is available on the MHS Guidance website under "College Credit Plus". The deadline for applying for these options April 1st each school year. A state mandated meeting is held at the high school in November.

SCHEDULE CHANGES

In order to plan staff and facilities within a public school system, it becomes necessary for commitments once made by the student to be binding. Schedule changes / request for course changes fall under two categories (1) school-initiated changes, and (2) student convenience changes.

1. *School-initiated changes* may be due to schedule conflicts, merit acceleration, credit recovery, or any related reason in which the guidance office or administration need to change a student schedule. This type of change can occur at any time.
2. *Student convenience changes* are considered to be any other type of schedule change request that is not initiated by the administration or guidance office. Reasons may include – but are not limited to – wanting a different elective, changing the class order, etc. Persons requesting such a change must obtain a "schedule change request form" in the guidance office and return the form – signed by a parent – before the end of the third day of any trimester for these changes to be considered. These changes will be considered after all required core area changes have been made and if space is available. Changes will not be considered if the requested class has a higher student population than the class in which the student is currently enrolled.

Under no circumstances will a student be permitted to make a course change FROM a course he/she requested as a primary or alternate course on the registration sheet TO a course that was NOT requested on the registration sheet.

SPECIAL EDUCATION

Special Education is specially designed instruction, at no cost to the parent, to meet unique needs of a student with a handicap. The student must be of legal school age, receive a multifaceted evaluation, meet the eligibility requirements for one or more of the program areas, and have an IEP (Individual Educational Plan) specifying instructional needs which can only be met through the provision of special education.

STATE & ADVANCED PLACEMENT TESTING

<u>Date</u>	<u>Test</u>	<u>Population</u>	<u>Schedule</u>
October 25, 2017	PSAT	All 10 th and selected 11 th	Regular
March 7, 2018	SAT	All 11 th grade	Regular
April 24, 2018	English 1 Part 1	All 9 th grade	10:00 start
	English 2 Part 1	All 10th grade	10:00 start
April 25, 2018	English 1 Part 2	All 9 th grade	10:00 start
	English 2 Part 2	All 10 th grade	10:00 start
May 1, 2018	Biology	All biology students	10:00 start
May 2, 2018	Algebra	All algebra students	11:00 start
	Geometry	All geometry students	11:00 start
May 3, 2018	US History	All 10 th grade students	10:00 start
	US Government	All 11 th grade students	10:00 start

<u>Date</u>	<u>Test</u>	<u>Testing Location</u>	<u>Report Time</u>
May 7, 2018	AP Chemistry	Board Office	7:30 am
	AP Psychology	Board Office	11:30 am
May 9, 2018	AP English Lit	Board Office	7:30 am
May 10, 2018	AP Government	Board Office	7:30 am
May 11, 2018	AP US History	MHS	7:30 am
May 14, 2018	AP Biology	Board Office	7:30 am
	AP Physics	Board Office	11:30 am
May 15, 2018	AP Calculus	Board Office	7:30 am
	AP Computer Sci	Board Office	11:30 am
May 16, 2018	AP English Lang	Board Office	7:30 am

WEIGHTED GRADING SYSTEM

As adopted by the Maumee Board of Education on December 15, 1986, the 4-point weighted system is in effect. This is an effort to have Maumee High School students compete on a more equal basis with students from area high schools for college admissions and scholarships. Under this grading system; one additional quality point will be applied for the grades of A or B in all Honors and Advanced Placement (AP) courses as well as some CC+ courses as identified by the administration and guidance staff and approved annually by the Board of Education. (See course listing below). Dual grading systems will be maintained, one based on a regular 4-point system (A = 4, B = 3, C = 2, D = 1, F = 0) and one based on a weighted system which gives an additional point to the grades of A and B (A = 5, B = 4, C = 2, D = 1, F = 0) in the courses indicated. The 4-point weighted system is used to compute and report grade point averages and class ranks for college admission and scholarship purposes. The regular 4-point system will be used to compute and report grade point averages and class ranks for ALL other purposes.

COURSES TO RECEIVE WEIGHTED

A (5 POINT) AND B (4 POINT) GRADES

English 1 Honors	Spanish 1 Honors	Geometry Honors
English 2 Honors	Spanish 2 Honors	Algebra 2 Honors
English 3 Honors	Spanish 3 Honors	Pre-Calculus Honors
AP English Literature & Composition	Spanish 2010 (CC+)	AP Calculus (AB)
Intro to Academic Writing (CC+)	Spanish 2020 (CC+)	AP Calculus (BC)
Academic Writing (CC+)	German 1 Honors	AP Computer Science A
Modern World History Honors	German 2 Honors	Biology Honors
AP US History	German 3 Honors	Chemistry 1 Honors
AP American Government	German 2010 (CC+)	AP Chemistry
Principles of Sociology (CC+)	German 2020 (CC+)	AP Biology
AP Psychology	AP Studio Art 2-D	AP Physics

ATTENDANCE POLICY

The Maumee City Schools, through the tenets of Ohio Administrative Code (3301-18-01) AND Ohio House Bill 410, set the statewide attendance target rate of 93% for all students and establishes truancy protocols for those who fall below that target. In an effort to reach that target, the Ohio Department of Education allows school boards of education to establish an attendance policy that is tied to the awarding of academic credit. Students who do not meet this requirement will not be eligible to receive academic credit for courses taken. In a trimester, this equates to 4 days of accumulated absence under the category of **absences counting towards the 4-day limit** per trimester. Students will receive a warning letter when they have reached 3 days of accumulated absence under the category **absences counting toward the 4-day limit** per trimester. Once a student surpasses 4 absences in the trimester, the student will lose academic credit and 1 or more earned exam waivers. Truancy – a term defined by Ohio HB 410 – gives guidance to school districts on when legal intervention is appropriate for enforcing compulsory attendance laws. There is no such thing as a “permanent medical excuse”. A doctor must excuse students on a per day basis. The presumption of a “permanent medical excuse” implies that the student may need to be evaluated for a suspected medical disability.

Absences **NOT** counting towards the 4-day limit (excused confirmed absences):

- *Medical – Confirmed (Signed Dr.'s note of excuse required for every date of absence)
- *Family Illness – Confirmed (Signed Dr.'s note of excuse required for every date of absence)
- *School sponsored field trip
- *College Visit or Job Shadow – 2 excused days for students in grades 9 & 10, 3 excused days for students in grades 11 & 12 (Documentation from employer or college visited required for excusal)
- *Court Appointment – Confirmed (Court letter of excuse required)
- *Serving as an election precinct worker – Confirmed (note required from precinct supervisor)
- *Quarantine of Home (note required from Lucas County Health Department)
- *Death of Immediate Family Member
- *Observation or celebration of a bona fide religious holiday.
- *In-school reassignment
- Out-of-school suspension

Absences counting towards the 4-day limit (excused unconfirmed absences/unexcused absences):

- *Medical or Personal Illness without a Dr.'s note of excuse (excused by a parent)
 - *Family Illness without a Dr.'s note of excuse (excused by a parent)
 - *College Visit – Unconfirmed/no note or documentation
 - *Court Appointment – Unconfirmed/no note or documentation
 - *Death of a non-immediate family member or friend
 - Family Vacation / Convenience
 - Truancy
 - Unexcused Absence
 - Other absences not classified as “excused” above (oversleeping, car troubles, missed bus, etc.)
- * **Homework, tests, quizzes, and in-class assignments** missed due to absences through any of the categories marked by an asterisk (*) above can be made up for full credit under the following conditions: (a) The student/parent must contact the teacher directly or through the guidance office to arrange for a list of assignments missed, and (b) Typically the student will have one (1) additional day upon return from an absence to complete all required classroom/paper work and turn it in to the teachers regardless of the number of days missed unless different arrangements have been made with the guidance office after condition. If missed assignments were available to the student at home (google classroom site, reading assignment, etc.), it is assumed that the student will have access to these materials at home and no extension of deadlines will be permitted. Student are not granted any additional time for quizzes or tests missed and must complete those upon the day of return. Teachers are not required to accept any assignments that are turned in later than this interval of time.
- Categories above **NOT** marked with an asterisk are those in which the teacher has complete discretion on whether the test, quiz, homework, or in-class assignment can or cannot be made up. In the cases of “truancy”, “unexcused absences”, or “out-of-school suspension”, no academic credit will be awarded for any missed work regardless. Missed work will be marked as a “zero” in the grade book with natural grade implications for the overall course grade.

Full Day Absences will be applied to all 5 courses.

Period and Partial Day Absences will be applied to the courses that were missed by the absence.

First Period Unexcused Tardies / Lates of more than 30 minutes (8:13 am) will result in a recorded unexcused absence for the class in which the tardy occurred. Two “free” late arrivals of 30 minutes or less – per trimester - will be permitted before disciplinary action and/or exam waiver removal.

NOTIFICATION & LOSS OF ACADEMIC CREDIT

Excessive school absence will result in the loss of all academic credit for the trimester as well as possible school discipline, removal of earned exam waivers, and/or referral to Juvenile Court. Loss of academic credit can occur in one course only or up to as many as all courses for the trimester depending on the nature of the absences. Once the student surpasses the 4th day in absences counting towards the absence limit, academic credit is lost. A "Loss of Academic Credit" letter will be sent out on as soon as possible. It may be possible that, should the student hit the limit on excessive absence at the very end of the trimester, the parent may not be informed until after the trimester has ended. Once the 3-day warning has been received, it is the responsibility of the student and parent to keep good track of school absences that may result in a loss of credit status. The false reporting of absence will be considered as truancies by the office. Truancy – a term defined by Ohio Revised Code – gives guidance to school districts on when legal intervention is appropriate for enforcing compulsory attendance laws (i.e.: deploying a Truancy Officer and/or making a referral to Juvenile Court).

REPORTING OF ABSENCE

Parents are required to call the high school at 419-893-8778 to report student absences. Student absences should be reported by 8:00 am on the day of the absence. Any high school secretary can take the report from the parent or a message may be left on the automated system. Per state law, the school attendance office will attempt to call parents of absent students prior to 8:45 am if no report has been made to the school. Written explanations of student absences are not required if the parent has called the high school.

However, written excuses are necessary when the parent was unable to call to report the absence on the day the absence occurred. The notes should be taken to the attendance secretary on the first day the student returns to school after his absence.

Absences unreported via phone or excuse note will be considered unexcused/truant. Students who are determined unexcused for reasons such as: over-sleeping, car problems, missing the bus, etc. will receive school discipline, and removal of earned exam waivers.

EXCUSED LATE ARRIVALS AND EARLY DISMISSALS FROM SCHOOL

If a student is late to school or must be released early due to an excused absence (Ex. Doctor's appointment), the parent should provide the office with a note explaining the absence. Early dismissal notes should also include the exact time of release as well as if the student or parent will be providing transportation. For the absence to be regarded as "excused confirmed" and not count towards the 4-day limit in any particular class, appropriate documentation must be provided within 24 hours.

ATTENDANCE AND ACTIVITIES

Students must be in attendance for a minimum of two periods of the school day to be eligible to attend or participate in extra-curricular activities and athletic events. Exceptions may be made by the high school administration prior to participation in the event. Students and parents should contact an administrator immediately if there is a question regarding attendance and/or participation.

FAMILY VACATIONS DURING SCHOOL DATES

Absence from school for student and/or parent personal convenience is not considered "excused confirmed" under the school attendance laws of the State of Ohio. Therefore, family vacation absences will be considered **unexcused** and will count towards the 4-day limit. Lack of informing the school of a personal vacation is considered **truancy** and will be handled as such. It is incumbent on the student & parents to check with the office prior to the planning of a vacation to see if the number of vacation days would result in a loss of academic credit and/or earned exam waivers. If this is the case, the student will be advised not to take the vacation.

The school must be notified before a convenience absence or vacation absence is taken. The procedures listed below must be followed so that the convenience absence or vacation absence is not counted as a truancy:

1. The student must obtain a "Convenience Absence Application" from the main office prior to the absence.
2. The "Convenience Absence Application" must be filled out by the student, his or her teachers, and a parent/guardian prior to the absence.
3. After completing the form, it must be presented to the principal's office for final approval prior to the convenience absence.

Teachers are not required to grade, examine, or correct any work done by the pupil during the absence. Teachers are also not required to provide any homework, notes, quizzes, tests, etc. in advance of a planned convenience absence. Lastly teachers are not required to provide opportunities to make up work missed by the convenience absence. The school can assume no responsibility for a drop in grades suffered by a pupil who is absent due to personal convenience.

TRUANCY

Ohio House Bill 410 clearly defines truancy in the following ways:

Habitual Truant – any child who is absent from school without a legitimate excuse for the following number of hours (RC 2151.011):

- 30 or more consecutive hours
- 42 or more hours in one school month
- 72 or more hours in one school year (12 days)

Unruly Child – a habitual truant who has not yet been adjudicated.

Delinquent Child – a child who violates a court order regarding the child’s habitual truancy.

A parent who allows a child to be habitually truant or does not enforce state compulsory attendance laws can also be charged and adjudicated.

The Board of Education can request that the Registrar of Motor Vehicles suspend the drivers license, temporary drivers permit, or the opportunity to obtain such permit for habitually truant students.

A parental phone call does not necessarily constitute a “legitimate absence excuse” under law.

DISCIPLINARY CODE OF CONDUCT

The Board of Education acknowledges that conduct is closely related to learning, i.e., an effective instructional program requires an orderly school environment.

The Board believes that the best discipline is self-imposed and that students should learn to assume responsibility for their own behavior and the consequences of their actions.

The Board shall require each student of this district to adhere to the administrative guidelines promulgated by the administration and to submit to such disciplinary measures as are appropriately assigned for infraction of those rules.

This Code of Conduct is in effect while students are under the authority of school personnel or involved in any school activity. This includes but is not limited to school busses and property under control of school authorities, and while at interscholastic competitions, extracurricular events, or other school activities or programs. In addition, this Code of Conduct includes (1) misconduct by a student that occurs off school district property but is connected to activities or incidents that have occurred on school district property, and (2) misconduct by a student that, regardless of where it occurs, is directed at a district official or employee or the property of an official or employee.

In accordance with Substitute House Bill No. 421 and under the Ohio Revised Code, Section 3313.661, the following Student Discipline Code for the Maumee City School District has been formulated. Violation of the Code of Conduct may result in verbal or written warning or reprimand, demerits, removal of earned exam waivers, referral to guidance counselor, parental contact or conference, detention, in-school reassignment, Saturday school detention, community service, emergency removal, referral to law enforcement agencies, out-of-school suspension, or expulsion.



OFFENSE

ACTION

- 1. Class truancy
Three demerits
- 2. Failure to comply with a teacher punishment
One demerit & the teacher's punishment must be served
- 3. Student in an unauthorized area
Three demerits
- 4. Dress Code Violations
Three demerits, student will not be permitted to return to class until clothes are changed. Second and subsequent offenses will result in 6 demerits
- 5. Cafeteria disturbances
One to fifteen demerits
- 6. Leaving school building without permission
Six demerits
- 7. Leaving a class without teacher's permission and/or knowledge
Three demerits
- 8. Miscellaneous offenses
One to fifteen demerits
- 9. Public display of affection
First offense-warning
Second offense three demerits
Third offense six demerits
- 10. Insubordination
One to fifteen demerits
- 11. Classroom disturbances
One to five demerits
- 12. Use of laser lights, iPods/MP3 Players, etc. in or at restricted times or areas.
Three demerits & confiscation of device. Parent must pick up the confiscated item for the second and subsequent offenses and the student will receive 6 demerits.
- 13. Driving/Parking violations
Three demerits for first offense. Towing and/or suspension of driving/parking privileges for subsequent offenses.
- 14. Unexcused tardy to school
No consequence for the first two (2) per trimester. Additional tardies will result in loss of earned exam waivers, One to Three Demerits, and/or Saturday school detention.
- 15. Acceptable Use Policy (cell phones, pictures,
Confiscation, Loss of privilege, and/web usage, video taping) or 1-15 demerits and/or appropriate discipline commensurate to the offense. Subsequent violations will result in parent having to pick up the confiscated device.

Students who do not receive any demerits for a whole month will have 3 demerits subtracted from their demerit total.

First Accumulation Experience (15 demerits)

- at 7 demerits Dean of Students notifies parents
- 15 demerits Saturday Detention

Second Accumulation Exp.(12 demerits)

- at 6 demerits Dean of Students notifies parents
- 3 day in-school reassignment

Third Accumulation (10 demerits)

at 6 demerits Dean of Students notifies parents
10 demerits 5 day in-school reassignment

Fourth Accumulation (5 demerits)

at 5 demerits 10 day in-school reassignment

Fifth Accumulation (5 demerits)

at 5 demerits 3 day out-of-school suspension.
possible recommendation for expulsion

Sixth Accumulation (5 demerits)

at 5 demerits 5 day out-of-school suspension
12 demerits recommendation for expulsion

A student who returns from an expulsion will be subject to the following levels and consequences for the remainder of that school year.

First Accumulation (10 demerits)

at 5 demerits Dean of Students notifies parents
10 demerits 5 day in-school reassignment

Second Accumulation (5 demerits)

at 5 demerits 10 day in-school reassignment

While understanding the student's basic constitutional rights—such as the right to speak and express opinions, even if unpopular—the Code is to ensure that an individual will not deprive or disrupt the educational process of others.

Parents will generally not be contacted for each incident involving demerits (warning points), but will be contacted when a disciplinary action has or is close to being assigned.

The Penta Career Center is an extension of our school program; therefore, students who elect to attend the career center are subject to disciplinary action based upon the student Code of Conduct of either Maumee High School and/or the Penta Career Center. Consequently, conduct and/or involvement in any activity that may or does result in disciplinary action by one school may be grounds for similar disciplinary action by the other school INCLUDING athletic coding.

A VIOLATION OF ANY RULE MAY RESULT IN DISCIPLINARY ACTION, INCLUDING REMOVAL, SUSPENSION, OR EXPULSION

- Rule 1 A student shall not possess, transmit, conceal, consume, or show evidence of consumption, or offer for sale any alcoholic beverage, illegal drug, unprescribed drug, counterfeit drug, or drug-related paraphernalia. A student needing to have a prescribed or non-prescription drug/medication in his/her possession for health reasons shall register such drug/medication with the school principal or his/her designee.
- Rule 2 A student (K-12) shall not possess, use, transmit, or conceal tobacco.
- Rule 3 A student shall not cause or attempt to damage any school property.
- Rule 4 A student shall not haze, harass, coerce, physically threaten any student, staff, or faculty member or person.
- Rule 5 A student shall not damage and/or vandalize private property at a school activity, function, or a school-sponsored event off the school grounds.
- Rule 6 A student shall not participate in a fight in the school building, on school grounds, directly on his/her way to and from school, or at any school-related function or activity.
- Rule 7 A student shall not assault or behave in such a way as could cause physical injury to any party.
- Rule 8 A student shall not verbally assault, threaten, or use abusive and/or obscene language in addressing any person, the staff, faculty, or other students either verbally or in writing.

- Rule 9 A student shall not possess, handle, transmit, or conceal any dangerous weapon or any instrument capable or appearing to be capable of causing serious bodily injury to a person.
- Rule 10 A student shall not cause any school routine to be disrupted. This includes, but is not limited to, disruptions through acts of violence, bomb threats, false fire alarms, insubordination, use of explosives, or indecent exposure. This also includes disruptions to the programs in another school building after dismissal from his/her own school program. A student shall not ignite any combustible material or be party to such act in the school buildings or on school property.
- Rule 11 A student shall not engage in or be a party to the theft of private or school property while on school grounds or in the school buildings or at a school-related activity.
- Rule 12 A student shall not violate school board policy or school rules as outlined in individual school building rules and regulations (e.g., tardiness, truancy, insubordination, unauthorized use of automobiles, violations resulting in demerits, etc.)
- Rule 13 A student receiving multiple suspensions may be recommended for expulsion.
- Rule 14 A reassigned student, grades 6-12, may serve reassignment time in the reassignment classroom. Unexcused absences or refusal to attend reassignment will be treated as truant from school and could result in referral to the Children's Services Bureau and/or the Juvenile Court.
- Rule 15 A student shall not give or sign the name of another person for the purpose of misleading school personnel. When asked, the student must give accurate identification to school personnel. A student who has been expelled by another district, may be temporarily denied admission to the District's schools during the period of expulsion even if that student would otherwise be entitled to attend school with the District. Prior to denying admission, however, the superintendent shall offer the student an opportunity for a hearing to review the circumstances of the expulsion and any other factors the Superintendent determines to be relevant.

The Board designates the Superintendent as its representative at all hearings regarding the appeal of a suspension. The Board designates the Assistant Superintendent as its representative at all hearings regarding the appeal of an expulsion.

The Superintendent shall develop administrative guidelines which provide appropriate procedures for implementing this policy and ensure compliance with applicable statutes.

ACADEMIC HONESTY

Maumee High School recognizes its responsibility in the development of students as responsible citizens. As part of this development, Maumee High School encourages students to maintain a high standard of ethics, academic honesty, and sense of personal honor and integrity.

Maumee High School realizes that in society today, there has been a growing acceptance of unethical activities and standards. The High School, therefore, is encouraging its staff and students to foster positive attitudes toward an academic career with a foundation built upon high standards of academic honesty and integrity.

Maumee High School Supports a policy wherein any student found to be participating in academic dishonesty will be subject to disciplinary procedures.

Violations of academic honesty may include, but are not limited to the following:

1. Copying another student's work, whether handwritten or computer file, without the teacher's consent
2. Copying another student's answers from a quiz, test, in-class assignment or homework without the teacher's consent
3. Plagiarism in any manner
4. Using notes, textbook or cheat sheets on quizzes, tests, and daily assignments without teacher's consent
5. Aiding another student in any way to violate the academic honesty policy

The teacher reserves the right to permanently keep any assignment, quiz, test, project, computer disk, flash drive or any external memory device of a student who the teacher suspects is in violation of the academic honesty policy.

Penalties for violation may include any of the following:

1. A zero on the assignment, project, test or quiz on which the cheating occurred and loss of earned exam waivers.
2. A phone call to the parents
3. Demerits
4. Detention
5. Conference with or disciplinary action assigned by an administrator
6. Suspension
7. Loss of Computer lab privileges
8. Removal of earned exam waivers

ANTI-HARASSMENT

(BOARD POLICY 5517)

GENERAL POLICY STATEMENT

It is the policy of the Board of Education to maintain an education and work environment which is free from all forms of unlawful harassment, including sexual harassment. This commitment applies to all School District operations, programs, and activities. All students, administrators, teachers, staff, and all other school personnel share responsibility for avoiding, discouraging, and reporting any form of unlawful harassment. This policy applies to unlawful conduct occurring on school property, or at another location if such conduct occurs during an activity sponsored by the Board.

The Board will vigorously enforce its prohibition against harassment based on sex, race, color, national origin, religion, disability, age or any other unlawful basis, and encourages those within the School District community as well as third parties, who feel aggrieved to seek assistance to rectify the problems. The Board will investigate all allegations of harassment and in those cases where unlawful harassment is substantiated, the Board will take immediate steps to end the harassment. Retaliation against individuals who make good faith reports of harassment is prohibited. Individuals who are found to have engaged in unlawful harassment or retaliation will be subject to appropriate disciplinary action.

For purposes of this policy, "School District community" means students, administrators, teachers, staff, and all other school personnel, including Board members, agents, volunteers, contractors, or other persons subject to the control and supervision of the Board.

For purposes of this policy, "third parties" include, but are not limited to, guests and/or visitors on School District property (e.g., visiting speakers, participants on opposing athletic teams, parents), vendors doing business with, or seeking to do business with, the Board, and other individuals who come in contact with members of the School District community at school-related events/activities (whether on or off School District property).

DEFINITIONS: SEXUAL HARASSMENT

Pursuant to Title VII of the Civil Rights Act of 1964 and Title IX of the Educational Amendments of 1972, "sexual harassment" is defined as:

Unwelcome sexual advances, requests for sexual favors, and other verbal or physical conduct of a sexual nature, when:

- A. Submission to such conduct is made either implicitly or explicitly a term or condition of an individual's employment, or status in a class, educational program, or activity;
- B. Submission or rejection of such conduct by an individual is used as the basis for employment or educational decisions affecting such individual;
- C. Such conduct has the purpose or effect of interfering with the individual's work or educational performance; of creating an intimidating, hostile, or offensive working, and/or learning environment; or of interfering with one's ability to participate in or benefit from a class or an educational program or activity.

Sexual harassment may involve the behavior of a person of either gender against a person of the same or opposite gender.

Prohibited acts that constitute sexual harassment may take a variety of forms. Examples of the kinds of conduct that may constitute sexual harassment include, but are not limited to:

- A. Unwelcome sexual propositions, invitations, solicitations, and flirtations.
- B. Physical assault.
- C. Threats or insinuations that a person's employment, wages, academic grade, promotion, classroom work or assignments, academic status, participation in athletics or extra-curricular programs or events, or other conditions of employment or education may be adversely affected by not submitting to sexual advances.
- D. Unwelcome verbal expressions of a sexual nature, including graphic sexual commentaries about a person's body, dress, appearance, or sexual activities; the unwelcome use of sexually degrading language, jokes or innuendoes; unwelcome suggestive or insulting sounds or whistles; obscene telephone calls.
- E. Sexually suggestive objects, pictures, videotapes, audio recordings or literature, placed in the work or educational environment, which may embarrass or offend individuals.
- F. Unwelcome and inappropriate touching, patting, or pinching; obscene gestures.
- G. A pattern of conduct, which can be subtle in nature, that has sexual overtones and is intended to create or has the effect of creating discomfort and/or humiliation to another.
- H. Remarks speculating about a person's sexual activities or sexual history, or remarks about one's own sexual activities or sexual history.
- I. Inappropriate boundary invasions by a District employee or other adult member of the School District community into a student's personal space and personal life.

Not all behavior with sexual connotations constitutes unlawful sexual harassment. Conduct must be sufficiently severe, pervasive, and persistent such that it adversely affects an individual's employment or education, or such that it creates a hostile or abusive employment or educational environment.

NOTE: Sexual conduct/relationships with students by District employees or any other adult member of the School District community is prohibited, and any teacher, administrator, coach, or other school authority who engages in sexual conduct with a student may also be guilty of the criminal charge of "sexual battery" as set forth in Ohio Revised Code 2907.03. The issue of consent is irrelevant in regard to such criminal charge and/or with respect to the application of this policy to District employees or other adult members of the School District community.

OTHER UNLAWFUL HARASSMENT

Prohibited harassment on the basis of race, national origin, religion, disability, age or other protected characteristic occurs when unwelcome physical, verbal, or nonverbal conduct is based upon an individual's protected characteristic or characteristics and when the conduct has the purpose or effect of interfering with the individual's work or educational performance; of creating an intimidating, hostile, or offensive working, and/or learning environment; or of interfering with one's ability to participate in or benefit from a class or an educational program or activity. Such harassment may occur where conduct is directed at the characteristics of a person's protected characteristic such as slurs, nicknames implying stereotypes, epithets, and/or negative references relative to customs, language, manner of speaking, appearance, impairments or limitations.

REPORTS AND COMPLAINTS OF HARASSING CONDUCT

Members of the School District community and third parties are encouraged to promptly report incidents of harassing conduct to an administrator, supervisor or other School District official so that the Board may address the conduct before it becomes severe, pervasive, or persistent.

Members of the School District community or third parties who believe they have been unlawfully harassed by another member of the School District community or a third party are entitled to utilize the Board's complaint process. Initiating a complaint will not adversely affect the complaining individual's employment or participation in educational or extra-curricular programs. While there are no time limits for initiating complaints of harassment under this policy, individuals should make every effort to file a complaint as soon as possible after the conduct occurs while the facts are known and potential witnesses are available.

The names and titles of the Anti-Harassment Complaint Coordinators with whom complaints of sexual and other forms of unlawful harassment should be filed are set forth in the administrative guidelines that supplement this policy. The names and titles of these individuals will be published annually in the parent and staff handbooks and in the School District Annual Report to the public.

The Superintendent shall establish Administrative Guidelines describing the process for making a charge of harassment, a process for investigating claims of harassment, and a process for rendering a decision regarding whether the claim of harassment was substantiated. This Policy and the Administrative Guidelines will be readily available to all members of the School District community and posted in appropriate places throughout the School District.

Any Board employee who directly observes unlawful harassment of a student is obligated, in accordance with this policy, to report such observations to one of the Complaint Coordinators. Thereafter, the Complaint Coordinator must contact the student, if age eighteen (18) or older, or the student's parents if under the age eighteen (18), to advise s/he/them of the Board's intent to investigate the alleged misconduct, including the obligation of the Complaint Coordinator or designee to conduct an investigation following all the procedures outlined for a formal complaint.

PRIVACY/CONFIDENTIALITY

The School District will respect the privacy of the complainant, the individual(s) against whom the complaint is filed, and the witnesses as much as possible, consistent with the Board's legal obligations to investigate, to take appropriate action, and to conform with any discovery or disclosure obligations. All records generated under the terms of this policy and its related administrative guidelines shall be maintained as confidential to the extent permitted by law.

SANCTIONS AND MONITORING

The Board shall vigorously enforce its prohibitions against unlawful harassment. While observing the principles of due process, a violation of this policy may result in disciplinary action up to and including the discharge of an employee or the suspension/expulsion of a student. All disciplinary action will be taken in accordance with applicable State law and the terms of the relevant collective bargaining agreement(s). When imposing discipline, the Superintendent shall consider the totality of the circumstances involved in the matter, including the ages and maturity levels of those involved. Sanctions imposed by the Board and/or Superintendent shall be reasonably calculated to eliminate such conduct in the future.

In those cases where unlawful harassment is not substantiated, the Board may consider whether the alleged conduct nevertheless warrants discipline in accordance with other Board policies, consistent with the terms of the relevant collective bargaining agreement(s).

EDUCATION AND TRAINING

In support of this Anti-Harassment Policy, the Board promotes preventative educational measures to create greater awareness of unlawful discriminatory practices. The Superintendent or designee shall provide appropriate training to students, administrators, teachers, staff and other school personnel related to the implementation of this policy and its accompanying administrative guidelines. All training regarding the Board's policy and administrative guidelines and harassment in general, will be age and content appropriate.

BULLYING AND OTHER FORMS OF AGGRESSIVE BEHAVIOR

Harassment, intimidation, or bullying toward a student, whether by other students, staff, or third parties is strictly prohibited and will not be tolerated. This prohibition includes aggressive behavior, physical, verbal, and psychological abuse. The Board of Education will not tolerate any gestures, comments, threats, or actions which cause or threaten to cause bodily harm or personal degradation. This policy applies to all activities in the District, including activities on school property or while enroute to or from school, and those occurring off school property if the student or employee is at any school-sponsored, school-approved or school-related activity or function, such as field trips or athletic events where students are under the school's control, in a school vehicle, or where an employee is engaged in school business.

This policy has been developed in consultation with parents, District employees, volunteers, students, and community members as prescribed in R.C. 3313.666 and the State Board of Education's Model Policy.

Harassment, intimidation, or bullying means any intentional written, verbal, graphic, or physical act that a student or group of students exhibits toward another particular student(s) more than once and the behavior both causes mental or physical harm to the other student(s) and is sufficiently severe, persistent, or pervasive that it creates an intimidating, threatening, or abusive educational environment for the other student(s). Aggressive behavior is defined as inappropriate conduct that is repeated enough, or serious enough, to negatively impact a student's educational, physical, or emotional well being. This type of behavior is a form of intimidation and harassment, although it need not be based on any of the legally protected characteristics, such as sex, race, color, national origin, marital status, or disability. It would include, but not be limited to, such behaviors as stalking, bullying/cyberbullying, intimidating, menacing, coercion, name-calling, taunting, making threats, and hazing.

Harassment, intimidation, or bullying also means electronically transmitted acts (i.e., internet, e-mail, cellular telephone, text messaging) that a student(s) or a group of students exhibits toward another particular student(s) more than once and the behavior both causes mental and physical harm to the other student and is sufficiently severe, persistent, or pervasive that it creates an intimidating, threatening, or abusive educational environment for the other student(s).

Any student or student's parent/guardian who believes s/he has been or is the victim of aggressive behavior should immediately report the situation to the building principal or assistant principal, or the Superintendent. The student may also report concerns to teachers and other school staff who will be responsible for notifying the appropriate administrator or Board official. Complaints against the building principal should be filed with the Superintendent. Complaints against the Superintendent should be filed with the board president.

COMPLAINTS

Students and/or their parents/guardians may file reports regarding suspected harassment, intimidation or bullying. Such reports shall be reasonably specific including person(s) involved, number of times and places of the alleged conduct, the target of suspected harassment, intimidation, and/or bullying, and the names of any potential student or staff witnesses. Such reports may be filed with any school staff member or administrator, and they shall be promptly forwarded to the building principal for review, investigation, and action.

Every student is encouraged, and every staff member is required, to report any situation that they believe to be aggressive behavior directed toward a student. Reports may be made to those identified above.

All complaints about aggressive behavior will be promptly investigated. The building principal or appropriate administrator shall prepare a written report of the investigation upon completion. Such report shall include findings of fact, a determination of whether acts of harassment, intimidation, and/or bullying were verified, and, when prohibited acts are verified, a recommendation for intervention which may include mediation where appropriate, and includes any disciplinary action shall be included in the report. Where appropriate, written witness statements shall be attached to the report.

If the investigation finds an instance of harassment, intimidation, and/or bullying has occurred, it will result in prompt and appropriate remedial and or disciplinary action. This may include up to expulsion for students, up to discharge for employees, and exclusion for parents, guests, volunteers, and contractors, and removal from any official position and/or request to resign for Board members. Individuals may also be referred to law enforcement officials.

Retaliation against any person who reports, is thought to have reported, files a complaint, or otherwise participates in an investigation or inquiry concerning allegations of aggressive behavior is prohibited and will not be tolerated. Such retaliation shall be considered a serious violation of Board policy and independent of whether a complaint is substantiated. Suspected retaliation should be reported in the same manner as aggressive behavior. Making intentionally false reports about aggressive behavior for the purpose of getting someone in trouble is similarly prohibited and will not be tolerated. Retaliation and intentionally false reports may result in disciplinary action as indicated above.

If a student or other individual believes there has been aggressive behavior, regardless of whether it fits a particular definition, s/he should report it and allow the administration to determine the appropriate course of action.

This policy shall not be interpreted to infringe upon the First Amendment rights of students (i.e., to prohibit a reasoned and civil exchange of opinions, or debate, that is conducted at appropriate times and places during the school day and is protected by State or Federal law).

The complainant shall be notified of the findings of the investigation, and as appropriate, that remedial action has been taken. If after investigation, acts of bullying against a specific student are verified, the building principal or appropriate administrator shall notify in writing the parent/guardian of the perpetrator of that finding. If disciplinary consequences are imposed against such student, a description of such discipline shall be included in the notification.

Students, parents/guardians, and school personnel may make informal complaints of conduct that they consider to be harassment, intimidation, and/or bullying by verbal report to a teacher, school administrator, or other school personnel. Such informal complaints shall be reasonably specific including person(s) involved, number of times and places of the alleged conduct, the target of suspected harassment, intimidation, and/or bullying, and the names of any potential student or staff witnesses. A school staff member or administrator who receives an informal complaint shall promptly document the complaint in writing, including the information provided. This written report shall be promptly forwarded by the school staff member and/or administrator to the building principal for review, investigation, and appropriate action.

Students who make informal complaints as provided above may request that their names be maintained in confidence by the school staff member(s) and administrator(s) who receive the complaint. Anonymous complaints shall be reviewed and reasonable action shall be taken to address the situation, to the extent such action may be taken that (1) does not disclose the source of the complaint, and (2) is consistent with the due process rights of the student(s) alleged to have committed acts of harassment, intimidation, and/or bullying.

When a student making an informal complaint has requested anonymity, the investigation of such complaint shall be limited as is appropriate in view of the anonymity of the complaint. Such limitation of investigation may include restricting action to a simple review of the complaint subject to receipt of further information and/or the withdrawal by the complaining student of the condition that his/her report to be anonymous.

PRIVACY/CONFIDENTIALITY

The School District will respect the privacy of the complainant, the individual(s) against who the complaint is filed, and the witnesses as much as possible, consistent with the Board's legal obligations to investigate, to take appropriate action, and to conform with any discovery or disclosure obligations. All records generated under this policy and its related administrative guidelines shall be maintained as confidential to the extent permitted by law.

REPORTING REQUIREMENT

At least semi-annually, the Superintendent shall provide to the President of the Board a written summary of all reported incidents and post the summary on the district web site (if one exists). The list shall be limited to the number of verified acts of harassment, intimidation, and/or bullying, whether in the classroom, on school property, to and from school, or at school-sponsored events.

Allegations of criminal misconduct and suspected child abuse will be reported to the appropriate law enforcement agency and/or to Child Protective Services in accordance with statute. District personnel shall cooperate with investigations by such agencies.

NOTIFICATION

Notice of this policy will be **annually** circulated to and posted in conspicuous locations in all school buildings and departments within the District and discussed with students, as well as incorporated into the teacher, student, and parent/guardian handbooks. State and Federal rights posters on discrimination and harassment shall also be posted at each building. All new hires will be required to review and sign off on this policy and the related complaint procedure.

EDUCATION AND TRAINING

In support of this policy, the Board promotes preventative educational measures to create greater awareness of aggressive behavior, including bullying. The superintendent or designee shall provide appropriate training to all members of the School District community related to the implementation of this policy and its accompanying administrative guidelines. All training regarding the Board's policy and administrative guidelines and aggressive behavior and bullying in general, will be age and content appropriate.

To the extent that State or Federal funds are appropriated for these purposes, the district shall provide training, workshops, and/or courses on this policy for school employees and volunteers who have direct contact with students. Time spent by school staff in these training programs shall apply toward mandated continuing education requirements.

IMMUNITY

A School District employee, student, or volunteer shall be individually immune from liability in a civil action for damages arising from reporting an incident in accordance with this policy and R.C. 3313.666 if that person reports an incident of harassment, intimidation, and/or bullying promptly, in good faith, and in compliance with the procedures specified in this policy. Such immunity from liability shall not apply to an employee, student, or volunteer determined to have made an intentionally false report about harassment, intimidation, and/or bullying.

The Superintendent is directed to develop administrative guidelines to implement this policy. Guidelines shall include reporting and investigative procedures, as needed. The complaint procedure established by the Superintendent shall be followed.

POSITIVE BEHAVIOR INTERVENTION SUPPORTS

Each school building within the Maumee City Schools provides a system of positive behavior supports for students. Program and building rules are designed to promote citizenship, ensure safety of all and reduce problematic behavior. Each school building implements programs to reinforce appropriate student behaviors and analyzes discipline data in order to determine how to best promote appropriate student behaviors and diminish challenging behaviors. Teams at each building are trained in Crisis Prevention Intervention techniques for managing students who present unsafe behaviors. Limited physical restraint and seclusion are used only to maintain the safety of all and within the policies adopted by the Maumee Board of Education Board Policy 5630.01 in compliance with the Ohio Department of Education's Policy on Positive Behavior Intervention and Supports, and Restrain and Seclusion. Every instance of physical restraint and/or seclusion will be documented and reported to parents. If a parent/guardian believes that his/her child has been improperly physically restrained or placed into seclusion, the parent may file a written complaint with the Superintendent.

TEACHER ASSIGNED DETENTION SYSTEM

Teachers may elect to assign detentions for small classroom rules infractions such as tardies to class (2nd through 5th periods), classroom disturbances, missing homework, etc. The teacher has the authority to assign a length of detention that they deem appropriate based on the rule violated. The teacher also may elect to have the detention served with the teacher or the building administration before or after school. Students assigned a teacher detention generally have one week to complete the detention, but the individual teacher has the discretion to reduce that window of time. Detentions are served at the convenience of the teacher or administrator, not the student. If the student does not serve the detention within the allotted time window, a disciplinary report will be written and the student will be issued one demerit for not completing the detention plus an additional demerit for every day from then on until the detention is served.

DENIAL OF SCHOOL PRIVILEGES

Students at any grade level may be denied school privileges by the principal or his/her designee for a duration of time as determined by the principal or his/her designee and for any reason deemed appropriate by the principal or his/her designee. Such privileges may include, but not limited to, the following: eating with friends in the cafeteria, movement in classroom normally permitted students who exhibit good citizenship, moving freely in non-classroom areas of the school, attending school assemblies, dances, sporting events, club meetings, class trips, special events, graduation ceremony, attending and/or participating in extra-curricular and co-curricular activities.

IN-SCHOOL REASSIGNMENT PROGRAM (I.R.P)

The I.R.P. is an alternative to out-of-school suspension. The I.R.P. will allow a student to do work and receive credit, work on GradPoint courses, as well as to meet with a counselor to discuss behavior, attitudes, and strategies for avoiding repeat incidents. In addition, students on an IEP are still permitted to go to their Intervention Specialist's room for 1-hour per day for tutorial services. Instructional materials are sent to students in the I.R.P. and finished materials are collected to be graded by the teachers. The I.R.P. is used for disciplinary reasons, for sure, but the students are provided with academic and counseling supports to prevent recidivism and keep them on track to pass courses and graduate.

1. Hours for the I.R.P. are the same as a regular school day.
2. Students are responsible to bring all books and materials to the I.R.P. room for the duration of their reassignment. Students may bring appropriate reading material which can be used when school assignments are completed.
3. Students are to remain in the room, in their seat, quietly working on school assignments.
4. Lunch: Students will eat lunch in the I.R.P. room.
5. Students are responsible for returning finished work to I.R.P. supervisor. Following completion of assignments, the I.R.P. supervisor will return them to the teacher. Teachers will give appropriate credit for work completed. The student will receive no credit for work not completed.
6. While in attendance, each student shall observe the Student Discipline Code and the rules for the I.R.P. classroom.
7. Any violations while attending the I.R.P. classroom may lead to an out of school suspension.
8. Absence/Tardy: Any student absent from the I.R.P. will make up the day missed. Any student tardy up to one hour will make up the time missed.
9. Tests may be sent to the I.R.P. teacher to administer. Tests not sent by the classroom teacher will be made up following the re-assignment.
10. Assigned days not served at the end of the school year may be carried over to the next school year.

SATURDAY SCHOOL DETENTION

A Saturday detention will be assigned when students have accumulated the 1st level of demerits, which is 15 demerits, or when assigned for various disciplinary infractions. Saturday detentions will meet from 8:00 am until 12:00 pm in the high school. Students will be given instructions on where to enter the building and must bring school-related materials with them. Students who come to Saturday School Detention without work will be sent home and a new disciplinary consequence assigned. Doors open at 7:50 am. Students must be on time.

OUT OF SCHOOL SUSPENSION

Students who are issued an out of school suspension will receive no credit for academic work while they are serving their out of school suspension. This includes students who are removed from in school reassignment for not following directions.

EXPULSION

Students who are issued an expulsion, or removal from school for an extended period of time, for Code of Conduct violations will be withdrawn from the school. The expelled student is not permitted on school property or grounds nor are they permitted to be on another property connected to activities or incidents that have occurred on school district property including, but not limited to, locations of extra-curricular events, performances, or competitions.

PARTICIPATION IN SCHOOL-RELATED ACTIVITIES WHILE SERVING IN-SCHOOL REASSIGNMENTS, SUSPENSION OR EXPULSION

Students who are serving in-school reassignment or are suspended may not attend or participate in extra-curricular activities or athletic events during the length of their reassignment or suspension. A day of reassignment or suspension shall be defined as the twenty-four hour period beginning at 7:43am and ending at 7:43am the following day. Students whose in-school reassignments or suspensions are in affect over a weekend are not eligible to participate in activities over that weekend. For example: a student reassigned or suspended for Friday, Monday and Tuesday, would not be permitted to participate in activities over the weekend. A student whose last day of reassignment or suspension is on a Friday would not be allowed to participate until 7:43am Saturday morning. Extra-curricular activities include but are not

limited to athletic events, school sponsored dances, club meetings and other school sponsored activities, music performances (see administration for clarification), awards ceremonies, theater performances, graduation ceremony, and competitions. Students who are suspended out-of-school or expelled are not permitted to be on school district property or at another property connected to activities or incidents that have occurred on school district property including, but not limited to, locations of extra-curricular events, performances, or competitions.

STUDENTS AS ADULTS

Students who are 18 years of age or older are required to comply with all school regulations. An adult student may be dismissed for failure to maintain satisfactory attendance, academic progress or behavior as set forth in the school's conduct policies. All consents, waivers, etc. that are normally required of parents or guardians of minor students may be signed by the independent adult student. Students living at home with their parents must have parental permission in regard to attendance.

DRUG ABUSE AND ALCOHOL GUIDELINES

In recent years, a growing incidence of pupil involvement with drugs and alcohol has come to the attention of school officials. In response to this situation, we have composed the following guidelines in an attempt to deal with the issue of pupil involvement.

A student shall not possess, use, transmit, conceal or be under the influence of any unregistered drugs, narcotics, "look alike" counterfeit drugs, or alcohol.

This rule applies to school buildings school grounds, school busses, and/or during school-sponsored activities on or off school property.

Possession of apparatus or paraphernalia associated with the use of any unregistered drugs or narcotics is strictly prohibited on school property or at any school-sponsored function. Violation of this rule will result in suspension up to ten (10) days and/or referral for expulsion as well as referral to the Maumee Police for formal charges.

MAUMEE CITY SCHOOLS STUDENT DRESS POLICY (5511)

The question of proper student dress often presents itself, especially at the upper grade levels. In an attempt to avoid as many problems as possible, it seems proper to express here a philosophy in the hope that parents, students, and administration can cooperate toward the avoidance of severe differences of opinion over dress and grooming.

Parents also have a responsibility; actually, the primary responsibility. Their example and their teaching at home have a profound effect upon the child. The students, the parents, and the school officials working together on this or on any other problem can create a school society in which a positive and cooperative atmosphere prevails.

MAUMEE CITY SCHOOLS STUDENT DRESS POLICY

Student dress for school is a matter that is perhaps most appropriately decided by the students and parents. In general, the District's policy is that students are not allowed to dress in a manner that would detract from the educational process. Accordingly the District has adopted the following dress code for all students, and all students are expected to comply with the dress code.

The purposes of the dress code are as follows: to enhance school safety, support the learning environment, promote good behavior, avoid discipline problems and prepare students for the world of work. Any student who is questionably attired will be referred to the administration and parents may be contacted if necessary. Often, the student will be requested to change into clothing more suitable for school.

GENERAL GUIDELINES & RESTRICTIONS

Overall Appearance

- A. Clothing and appearance that brings undue attention, prompting disruption to the learning environment is not permitted. Clothing and appearance that is deemed inappropriate is at the discretion of the building administrator. (Examples: low-cut, plunging or revealing necklines, visible underwear, yoga pants/leggings that are revealing, etc.)
- B. Clothing or appearance that promote gang activity, drugs, alcohol, or tobacco is not permitted. Also, clothing that has obscenities, profane language, sexual innuendoes, degrading wording or display symbols of hate or oppression is not permitted.

- C. Students must dress appropriately to meet safety requirements in labs, physical education courses and industrial technology courses. The instructor will discuss the requirements in class.
- D. Tops and bottoms must overlap at all times, including when arms are raised overhead and when seated.
- E. Clothing that is torn, has holes, or rips is not permitted.

Top Garments

- A. Female shirts and dresses must have a collar, or sleeves, or both. (No low-cut, plunging, or revealing necklines).
- B. Male shirts must have both a collar and sleeves. Collars may be of the rib neck variety. These would include collars on T-shirts and crew neck sweatshirts.

Dresses, Skirts & Bottom Garments

- A. Dresses, skirts and shorts must be no more than three (3) inches above the kneecap.
- B. Pajamas or lounge pants are not permitted.

Footwear, Outerwear, Head Coverings

- A. Footwear must be worn at all times. For safety considerations, all footwear must be adequately secured to the foot with heels no higher than two (2) inches.
- B. Thong sandals (flip flops), slippers, shoes with retractable skates or other footwear with flexible, soft soles are not permitted.
- C. Head coverings of all types are prohibited indoors from the beginning until the end of the school day. (Head coverings include but are not limited to: hoods, hats, bandanas, do-rags and sweatbands). Exceptions may be made by the building principal as required by law to accommodate sincerely held religious beliefs.
- D. Outdoor apparel may not be worn in the building from the beginning to the end of the school day.

GUIDANCE SERVICES

Our purpose as guidance counselors is to help you better help yourself. We provide the following services:

1. **Counseling Service** - The counselors are available to meet with you to discuss any personal or academic concerns you may have. Any conversations you have with a counselor are confidential. When you feel the need for someone to talk to, contact a counselor.
2. **Parent Conference Service** - Counselors often meet with parents to inform them about their students' progress in school. Counselors provide a variety of services aimed at addressing barriers to student learning. If your parents wish to speak with one of the counselors, they can be reached at 419-893-8778.
3. **Information Service** - Located in the Guidance Office, the Guidance Website and school library is a tremendous amount of information on career planning and opportunities: colleges, technical schools, the armed services, community agencies, scholarships, financial aid etc. These materials are always available to you. If we do not have some of the information you want, perhaps we can help you get it.
4. **Group Counseling Service** - Several times during the school year the counselors will meet with you in groups to explain and administer tests, interpret test results, help with scheduling, discuss study skills, and work with career information, college applications, Penta County, etc.
5. **Evaluation Service** - During your years in high school, you will take a number of tests given by the counselors. The purpose of these tests vary, but the main intent is to help you better understand yourself. The counselors and teachers get useful information about you from these tests so as to help you
6. **Peer Tutoring Services** - An after-school peer tutoring service is available to students in the academic core areas. This is a free service but students are required to provide their own transportation home.
7. **Electronic Gradebook** - Parents and students are encouraged to use the electronic gradebook to access progress and current grades. The guidance office can assist in logging on or providing login/password information.
8. The counselors are here to assist you in any way they can. If you need some assistance, have a question, or just need someone to talk to, see a counselor.

COLLEGE ADMISSIONS COUNSELORS' VISITS

Each year a large number of colleges and universities send representatives to Maumee High School to speak with interested students. These colleges are invited to set up display tables in the cafeteria.

COLLEGE INFORMATION

Please see the Guidance Website for a complete guide to college planning.

COLLEGE VISITATIONS/JOB SHADOWING

Students are encouraged to visit a number of college campuses before deciding which to attend OR to arrange a job shadowing opportunity in a field in which the student is interested. School policy permits three days of confirmed excused absence (with proper documentation) for this purpose for juniors and seniors. Freshmen and sophomores may have two days of confirmed excused absence (with proper documentation) for this purpose. Students must obtain a College Visitation Permission OR Job Shadowing Permission form from the Guidance Office well in advance of the visit. It is the student/parent responsibility to arrange these experiences.

EDUCATIONAL OPTIONS

Once in a while a situation comes up that requires a student to earn credit toward graduation in a manner other than daily attendance at Maumee High School. These options might include:

1. summer school attendance
2. home instruction
3. correspondence courses
4. credit for extended travel
5. College Credit Plus (CC+)
6. credit flexibility

Credit flexibility options are designed for those students who demonstrate the ability, interest, and maturity to accept personal responsibility for their learning in a selected curricular area and have the opportunity to pursue it outside of Maumee High School with a Maumee BOE-approved program. The purpose of the credit flexibility option is to develop learners who devise their own research, learning objectives, and a plan whereby they will attain those objectives outside of the traditional classroom. The policy will provide a personalized educational opportunity for all students in which they will identify, acquire, and demonstrate the proficiency of their knowledge through agreed upon standards to earn graduation credit. Students will engage in activities beyond the boundaries of the classroom by taking part in an alternative learning experience to traditional "seat time" of classroom work, in which they will demonstrate identified learning standards. Students will be required to complete a Proposal for Credit Flexibility form in which they will define their educational goals, identify the standards they will demonstrate, and create a timeline for completion. Students may work independently or with a credit flexibility partner. Individuals and organizations wishing to partner with the student in an instructional plan will need to seek approval from the Maumee City Schools.

Permission to exercise any of these options must be documented and planned by a Maumee High School Guidance Counselor and approved by the Maumee High School Principal or Superintendent prior to implementation.

GUIDANCE WEBSITE

In order to deliver maximum information to all students and parents, we place pertinent information on our guidance website. Our website includes the following information: graduation requirements, college information and application procedures, scholarship searches, college representative visits, ACT/SAT codes and test dates, local college costs, financial aid, athletic eligibility and NCAA, CC+ information, schedule changes and procedures as well as helpful web site links. We also have the class power point presentations that we use with your students. Please take the time to visit and familiarize yourself with our site. This site can be accessed from the Maumee City Schools home page. If you wish information on any of these options, please see your guidance counselor.

MILITARY INFORMATION

The Guidance Department acts as liaison with the service academy representatives and with the different recruiting officers. Recruiters are entitled to student directory information. However, student may opt out of the list by checking the proper box on the electronic back-to-school forms.

SHADOWING

Students frequently request that a friend or relative from another school shadow them for a day. Student shadowing will only be permitted for the following reason. Students who are in the eighth grade living in the Maumee school district - but attending a school other than a Maumee City School - and interested in attending Maumee High School may shadow a student for one day. The parent of the child wishing to shadow must make a request to the guidance department of Maumee High School one week prior to the shadowing date. Students who do not receive permission prior to their shadow date will not be permitted to shadow.

SUMMER SCHOOL

Summer school is available in area schools. Students should consult their guidance counselors for proper placement in classes. Applications for summer sessions are usually available in the Guidance Office by mid-April.

PENTA CAREER CENTER

How about a career-technical program?

A career is an occupation which is a manner of work to earn a living. The earning potential in the career-technical trades is excellent. Penta Career Center offers one and two year programs to prepare you for a career upon graduation from Maumee High School.

Q: What is Penta County Career Center?

A: It is an extension of Maumee High School along with 15 other high schools. You will graduate with a Maumee High School diploma.

Approximately 20% of the students graduating from Maumee have taken a Penta program.

1. Penta offers courses to sophomores, juniors, and seniors that will prepare them to enter a career.
2. Penta has six basic areas of interest:
 - 1) Applied Manufacturing Technologies
 - 2) Arts & Communications
 - 3) Business Management & Information Technology
 - 4) Industrial & Engineering Systems
 - 5) Health Services
 - 6) Human Services
 - 7) Environmental & Agricultural Systems

Q: What do I have to do to prepare for the Penta experience?

A: Earn the following credits during your first two years at Maumee High School:

Two credits of English

Two credits of Math

Two credits of Science

Two credits of Social Studies

One unit of credit in Health and Physical Education

Q: What programs are available at the Penta County Career Center?

A: There are many programs of study available at the Penta County Career Center. Some programs have competitive entry requirements and admission may depend on student ability.

Advanced Manufacturing Technologies

Automotive Collision Repair

Automotive Technology

Computer-Aided Design

Construction Carpentry

Gas and Diesel Engine Systems

Hair Design

Heating and AC Technology

Information Technologies Academy

Interactive Media

Construction Electricity
Construction Masonry
Construction Remodeling
Cosmetology
Culinary Arts
Dental Assistant
Digital Video Production
Early Childhood Education
Exercise Science/Sports Health Care
Floral Design/Greenhouse Production

Landscape & Turf Mgmt.
Marketing Education
Medical & Legal Office Management
Medical Technologies
Power Sports and Engine Systems
Public Safety/EMT-Fire Science
Public Safety (Criminal Justice)
Small Animal Care
Teaching Professions
Welding

Q: What can Penta do for me?

A: Penta can teach the skills needed for gainful employment, provide actual work experience - with pay in some cases, prepare the student for apprenticeship programs, offer a change from the total classroom environment of a regular high school, provide you a high school diploma while you learn an occupation and prepare you for advanced studies in the future.

Q: How can I find out more about Penta?

- A: 1) From the Penta presentation given to all ninth and tenth graders.
2) Attend “Explore Penta Day” event in a career of your choice during the tenth grade.
3) Request a “Tech Tuesday” visit in spring.
4) See your counselor for more information.**

ON-LINE GRADING PROGRAM

ONLINE GRADEBOOK EXPECTATIONS

The online grading module is an integral instrument of communication between the students, parents, and teachers of Maumee City Schools. Parents and students have the ability to track the academic progress in each class during a grading period. Although this is an excellent resource for communication, one must realize there are limitations as to how this information can be used. Grades can fluctuate because of the various assignments and weights of each assignment. Due dates for assignments can change for a variety of reasons, including, progress of a particular class, interruptions to the school year, and the need to re-teach material. Knowing these limitations, it is important for parents to continue the practice of monitoring completed work, checking assignment books and reviewing graded assignments.

It is the belief of the Maumee City Schools staff that as students progress through the system they should begin to develop skills that include the organization and tracking of assignments and progress in each class. Students will develop these skills at various rates and competencies. As the students progress thru their school years, it is important to prepare students for post secondary experiences which will not afford them the benefit of the electronic gradebook. At the high school level the electronic gradebook should serve as a reminder and verifier.

You and your student will receive a username and password in a separate mailing. You will have separate accounts for each child in your household and may link these through the system. Please be careful to safeguard your account as it does contain access to sensitive information regarding your student. It is your decision if you'd like to share the account with another person. Maumee City Schools will not provide your account information to anyone other than you.

POSTING OF GRADES

Normal Assignments - Teachers will be required to post the grades of “normal assignments” within five (5) calendar days of the assignment due date listed in the PowerSchool grading program. “Normal assignments” are defined but not limited to homework, tests, daily work, quizzes, small group assignments, in-class assignments, etc. For the purpose of this requirement, days equal calendar days not school days.

Large Assignments - Teachers will be required to provide an approximate date as to when the grade for “large assessments/projects/assignments” will be posted to PowerSchool online grading program. The approximate date should be included with the assignment information. Although the posting to the online grading section may be longer than the 5 day requirement, teachers should post missing “large

assignments” on the PowerSchool online grading program within three (3) days after the assignment was collected.

If needed, parents are encouraged to contact teachers at any time with concerns or questions regarding academic performance of their child.

The guidance office can provide login/password information should you lose you access.

POSTING OF HOMEWORK DUE DATES

The online grading system used by the Maumee City Schools affords teachers the opportunity to post homework assignments for the upcoming week. Some courses, however, may be structured in such a way that this mode of information delivery is not possible. As such, the tracking of homework assignments remains the responsibility of the student primarily with the use of their agenda book. Parents are free to inquire of individual teachers as to the mode of homework notification used in a particular course.

SENIOR CLASS INFORMATION

COMMENCEMENT

The commencement exercise is usually held the last week of school at the Stranahan Theater. According to Board regulations, no student will be permitted to graduate or participate in the commencement exercises without first having fulfilled the requirements for graduation established by the State Department of Education and the Maumee Board of Education, have paid any outstanding fines and/or fees prior to the commencement date, and are not serving any disciplinary consequences that extend over the graduation weekend.

EARLY COMPLETION OF HIGH SCHOOL

It is the belief of the Maumee City Board of Education that most students will benefit from a basic planned four-year program of instruction in grades 9-12. However, individual cases may merit early graduation for pupils when all of the established procedures are met.

1. All graduation requirements, including minimum credit quantitative requirements for subject areas, must be completed, including meeting the State of Ohio assessment criteria.
2. The high school principal and guidance counselor shall verify that the pupil qualifies for graduation.
3. Diplomas will not be issued at times other than normally scheduled commencement dates.

Procedures:

1. Students desiring 11th trimester early graduation should first check with high school counselors to ensure that sufficient credits and meeting the State of Ohio assessment criteria will be completed prior to the date diploma would be granted.
2. Parents/guardians and/or students should request early graduation privilege using Application Form A.
3. The high school guidance counselor shall produce documentation that confirms that the student will meet graduation requirement and give to the high school principal.
4. Early graduation expectations must be agreed to by the parent/guardian and student. (Form B) Parents must provide a written request for early graduation to the guidance counselor.
5. The deadline for applying for early graduation shall be completed by May 1 of the calendar year prior to graduation.
6. The high school principal or his designee will notify the parent/guardian and the student of the decision.
7. Appeals of the decision of the principal shall be made to the Superintendent or his/her designee.
8. Exceptions to the above procedure must be approved by the Maumee City Board of Education. All exceptions must be for unusual and extenuating circumstances whereby the child’s best interests are the primary consideration. The following guidelines apply:
 - a. written application by the parent/guardian with specific reasons for the request.
 - b. All written application shall be reviewed by a committee consisting of two Board members and the Superintendent with a recommendation to be made to the entire Board of Education for their consideration.
 - c. The Board of Education will make the final determination relative to permitting exceptions to regular early graduation requirements.
 - d. All other graduation requirements must be met as prescribed in this Board of Education policy.

EARLY GRADUATE EXPECTATIONS

1. Extracurricular activities and interscholastic athletics are prohibited. The student may attend only as a spectator and then in general admission or reserved seat sections.
2. School dances are prohibited with the exception of the prom.
3. Must finish the first and second trimesters of the senior year regardless of weather conditions, calamity days, or work schedules.
4. If requirements - including the graduation testing requirements - and credits are not met, then the student must return the last trimester as a full time student.
5. The student is responsible for finding out about graduation practice dates, graduation announcement, and dates for distribution of caps and gowns.
6. The student must sign a statement that he/she examined and checked his/her own transcript.
7. Diplomas will be issued at the end of the school year commencement.
8. All school fees and fines must be paid.
9. All consequences for disciplinary infractions must be served prior to the last day of the term in which the student is graduating.

BREAKFAST AND LUNCH PROGRAM

Breakfast and lunch service are offered to all students. Maumee Schools participates in the National School Breakfast and Lunch Program. Applications for free and reduced lunches may be found on the MCS website or in the MHS office. **Applications may be turned in at any time during the school year.**

Payment for meals may be made on-line at k12paymentcenter.com or at meal service by check or cash. MCS knows the importance of students eating breakfast and lunch to prepare them for school. With this in mind, students are allowed to charge lunches. No charging is allowed at breakfast or for ala carte items. Students cannot exceed a charge balance of \$10.00. If a student will exceed \$10, they will be given an alternative lunch entrée. **All charges must be paid by the end of the year.**

LUNCH PERIOD REGULATIONS

1. Students may pack their own lunch or purchase a meal in the cafeteria. Students who meet government income guidelines are eligible for free or reduced price meals. Applications are available in the main office. Students are not permitted to receive fast-food delivery during the school day.
2. Students are not permitted to share lunch account numbers for any reasons. This would include free and reduced lunches. Using another student's numbers will be subject to disciplinary or legal action.
3. Students will throw away their garbage and stack their trays prior to exiting the cafeteria.
4. Students are expected to be orderly in the cafeteria at all times. They must also follow all directions given to them by the cafeteria supervisors. Students should conduct themselves in a mature and respectful manner.
5. Access to other parts of the building is by permission only. Students found in unauthorized areas are subject to school discipline.
6. Lunchroom disturbances or incidents of insubordinate behavior in the cafeteria are governed by the demerit system. Students who cause minor disturbances will be dealt with on an individual basis.
7. Students are not allowed to leave the school campus to visit area restaurants during the lunch periods.
8. All food must be consumed in the cafeteria. Vending machines will be provided for the students' convenience. Exceptions to this rule will be curriculum-based projects that are pre-approved by the administration.

BREAKFAST PROGRAM

Breakfast will be served in the cafeteria beginning at 7:15 am and will promptly close at 7:42 am. Lunch period rules 1-8 above will also apply to the breakfast service.

Penta Career Center students may participate in the breakfast program at Maumee High School, but must remain in either the cafeteria, entryway, or atrium in preparation for leaving for Penta.

COOPERATION WITH SAFETY SERVICE ORGANIZATIONS

It is the policy of the schools to cooperate with law enforcement agencies in the interest of the larger welfare of all citizens. The Maumee City Schools partner with the Maumee Police Department (Student Resource Officer), Lucas County Children's Services (student safety and welfare), Lucas County Juvenile Justice System (attendance/truancy), SAIL board (substance intervention and counseling) as well as other organizations.

FIRE DRILLS AND TORNADO DRILLS

The purpose of the fire drill is to clear the building quickly and in an orderly fashion. No serious fire is anticipated, since our building is fireproof, but an occasion might arise when panic could be avoided only by having all building occupants trained for orderly evacuation. Exits are assigned to each classroom. Everyone is expected to respond to the fire signal. Go far enough beyond the exits to permit all to get out of the building without delay. Return to the building on signal and go directly to class.

State law requires all schools to conduct tornado drills. When a tornado drill is announced by public address system all students will proceed to the ground floor of the building where they are to assemble in a corridor and rooms away from windows.

No student is to be in a gymnasium or auditorium or on the perimeter of the building where there are windows to the outside. Proper shielding of the head is by wrapping the hands and arms around it for protection and will be required during drills.

LOCKDOWN DRILLS / A.L.I.C.E DRILLS

State law requires all schools to conduct lockdown drills and local law enforcement agencies are in complete control of the drill from start to finish. Local law enforcement agencies may use this drill for training purposes and/or to conduct random sweeps.

FIRE/TORNADO WARNING/LOCKDOWN EVENT

When an actual emergency is declared the school environment will be secured by law enforcement, staff, and school administration. Students will not be permitted to leave the premises until the principal has received the "all clear" from the local law enforcement agency and has accounted for the whereabouts of all students. **Parents are NOT permitted to remove students from the school or school grounds during any type of drill or actual emergency.**

SEARCH AND SEIZURE

(BOARD POLICY 5771)

The Board of Education recognizes that the privacy of students or his/her belongings may not be violated by unreasonable search and seizure and directs that no student be searched without reasonable suspicion or in an unreasonable manner.

The Board acknowledges the need for in-school storage of student possessions and shall provide storage places, including desks and lockers, for that purpose. Students may lock them against incursion by other students, but in no such places shall students have such an expectation of privacy as to prevent examination by a school official. The Board permits the school principals to conduct a regular search at least annually of all such storage places.

School authorities are charged with the responsibility of safeguarding the safety and well-being of the students in their care. In the discharge of that responsibility, school authorities may search the person or property, including vehicles, of a student, with or without the student's consent, whenever they have reasonable suspicion to suspect that the search is required to discover evidence of a violation of law or of school rules. The extent of the search will be governed by the seriousness of the alleged infraction and the student's age.

This authorization to search shall also apply to all situations in which the student is under the jurisdiction of the Board.

Search of a student's person or intimate personal belongings shall be conducted by a person of the student's gender, and only in exceptional circumstances when the health or safety of the student or of others is immediately threatened.

The Board also authorizes the use of canines, trained in detecting the presence of drugs, when the Superintendent has reasonable suspicion that illegal drugs may be present in a school. This means of detection shall be used only to determine the presence of drugs in locker areas and other places on school property where such substances could be concealed. Canine detection must be conducted in collaboration with law enforcement and is not to be used to search individual students unless a warrant has been obtained prior to the search.

Except as provided below, a request for the search of a student or a student's possessions will be directed to the building principal or those specifically designated, who shall notify the Superintendent and seek the freely offered consent of the student to the inspection. Whenever possible, a search will be conducted by the principal in the presence of the student and a staff member other than the principal. A search prompted by the reasonable belief that health and safety are immediately threatened will be conducted with as much speed and dispatch as may be required to protect persons and property.

The principal shall be responsible for the prompt recording in writing of each student search, including the reasons for the search; information received that established the need for the search and the name of informant, if any; the persons present when the search was conducted; any substances or objects found; and the disposition made of them. The principal shall be responsible for the custody, control, and disposition of any illegal or dangerous substance or object taken from a student.

STUDENT EXPRESSION

(BOARD POLICY 5723)

In accordance with Board Policy **5722** and Policy **9700**, students have the right, protected by the First Amendment to the U.S. Constitution, to exercise freedom of speech. This includes the right to distribute or display, at reasonable times and places, unofficial written material, petitions, buttons, badges, or other insignia, except expression which:

- A. is obscene to minors;
- B. is libelous;
- C. is pervasively indecent or vulgar;
- D. advertises any product or service not permitted to minors by law;
- E. constitutes insulting or fighting words, the very expression of which injures or harasses other people (e.g., threats of violence, defamation of character or of a person's race, religion, or ethnic origin);
- F. presents a clear and present likelihood that, either because of its content or the manner of distribution or display, it will cause a material and substantial disruption of school or school activities, a violation of school regulations, or the commission of an unlawful act.

Distribution or display of material in any of the above categories is prohibited on school premises or at any school-related event.

PROCEDURES

Any student wishing to distribute or display unofficial material must first submit for approval a copy of the material to the principal twenty-four (24) hours in advance of desired distribution/display time, together with the following information:

- A. name of the student or organization
- B. date(s) and time(s) of day of intended display or distribution
- C. location where material will be displayed or distributed
- D. the grade(s) of students to whom the display or distribution is intended

The principal should either approve the material or indicate how it violates the guidelines listed above or the time, place, and manner restrictions listed below. If permission to distribute or display the material is denied, the student shall have the opportunity to make necessary revisions and/or deletions. Permission to distribute or display material does not imply approval of its contents by either the School, the administration of the School, or the Board.

TIME, PLACE, AND MANNER OF DISTRIBUTION OR DISPLAY

The distribution or display of written material shall be limited to a reasonable time, place, and manner as follows:

- A. No material may be distributed or displayed during the time or at the place of a school activity if it is likely to cause a substantial disruption of that activity.
- B. No material may be distributed or displayed if it blocks the safe flow of traffic within corridors and entrance ways of the school.

DEFINITIONS

The following definitions shall apply:

- A. "Obscene to minors" is defined as:
 - 1. the average person, applying contemporary community standards, would find that the written material, taken as a whole appeals to the prurient interest of minors;
 - 2. the material depicts or describes conduct that is patently offensive to prevailing standards in the adult community concerning how such conduct should be presented to minors;
 - 3. the material, taken as a whole, lacks serious literary, artistic, political, or scientific value for minors.
- B. "Minor" means any person under eighteen (18) years of age.

DISCIPLINARY ACTION

Distribution or display by any student of non school-sponsored material prohibited by these guidelines will be halted and disciplinary action will be taken in accordance with the procedures contained in AG 5600 and AG 5610. Any other party violating this guideline will be requested to leave the school property immediately and, if necessary, the police will be called.

SCHOOL-SPONSORED PUBLICATIONS AND PRODUCTIONS

(BOARD POLICY 5722)

The Board of Education sponsors student publications and productions as means by which students learn, under adult direction/supervision, the rights and responsibilities inherent when engaging in the public expression of ideas and information in our democratic society.

For purposes of this policy, "school-sponsored student media" shall include both student publications and productions. "Student publications" shall include any written materials, (including, but not limited to, banners, flyers, posters, pamphlets, notices, newspapers, playbills, yearbooks, literary journals, books, and t-shirts and other school-sponsored clothing), as well as material in electronic or on-line form (including, but not limited to, websites, web logs ("blogs"), video or audio clips, and newsletters or announcements transmitted by e-mail, wireless broadcast or other similar distribution/dissemination). "Student productions" shall include vocal and theatrical performances, impromptu dramatic presentations, or any electronic media (including, but not limited to, radio and television programs, podcasts, and other video or audio productions that are recorded for re-broadcast or broadcast in real time using any available broadcast technology). Further, the term "publication" shall include distribution and dissemination of a student publication; and the term "performance" shall include presentation and broadcast of a student production.

The following speech is unprotected and prohibited in all school-sponsored student publications and productions: speech that is defamatory, libelous, obscene or harmful to juveniles; speech that is reasonably likely to cause substantial disruption of or material interference with school activities or the educational process; speech that infringes upon the privacy or rights of others; speech that violates copyright law; speech that promotes activities, products or services that are unlawful (illegal) as to minors as defined by State or Federal law; and speech that otherwise violates school policy and/or State or Federal law. The Board authorized the administration to engage in prior review and restraint of school-sponsored publications and productions to prevent the publication or performance of unprotected speech.

All school-sponsored student publications and productions are nonpublic forums. While students may address matters of interest or concern to their readers/viewers, as nonpublic forums, the style and content of the student publications and productions can be regulated for legitimate pedagogical, school-related reasons. School officials shall routinely and systematically review and, if necessary, restrict the style and/

or content of all school-sponsored student publications and productions prior to publication/performance in a reasonable manner that is neutral as to the viewpoint of the speaker. Legitimate pedagogical concerns are not confined to academic issues, but include the teaching by example of the shared values of a civilized social order, which consists of not only independence of thought and frankness of expression but also discipline, courtesy/civility, and respect for authority. School officials may further prohibit speech that is ungrammatical, poorly written, inadequately researched, biased or prejudice, vulgar or profane, or unsuitable for immature audiences.

School-sponsored student media may not be published/performed outside the school community (i.e. publication/performance is limited to students, staff and parents/family members) except with prior approval of the building principal.

Advertising is permitted in all school-sponsored student publications/productions.

Advertisements submitted for publication or inclusion in a production shall be reviewed by the class/activity advisor and/or the building principal. The Superintendent retains the final authority to determine whether an advertisement is appropriate and will be included in a publication/production. Advertisements may be rejected for legitimate pedagogical school-related reasons unrelated to the viewpoint of the advertiser (e.g., the advertisement encourages action that would endanger the health and safety of students).

GENERAL PROHIBITIONS

Regardless of their status as non-public or limited-purpose public *forums*, the Board prohibits publications, productions and advertisements that:

- A promote, favor, or oppose any candidate for election or the adoption of any bond issue, proposal, or question submitted at any election;
- B fail to identify the student or organization responsible for the publication/performance;
- C solicit funds for non-school organizations or institutions when such solicitations have not been approved by the Board.

RESPONSIBLE USE POLICY FOR TECHNOLOGY AND NETWORK USE

(BOARD POLICY 5136)

* Written below is the abridged version of policy 5136 which can be viewed in it entirety at www.neola.com/maumee-oh/, or a complete printed copy can be made available upon request.

Technology tools and resources profoundly influence education, the work place, and everyday life. Users of technology are challenged with discerning appropriate boundaries of use and recognizing potential risks of constantly emerging technologies. It is the Maumee City School District's intention to provide a framework of digital citizenship by which all technology users within the District will co-exist. This document establishes a standard of expected behavior of good digital citizens.

Elements of Digital Citizenship

- A. *Guiding Question: Does your behavior represent good work ethic and productivity identify appropriate uses of technology:*
- B. *Guiding Question: Does your behavior diminish technology resources for other users in the District community?*
- C. *Guiding Question: Does your product improve knowledge and understanding?*
- D. *Guiding Questions: Does your conduct impact the safety, security or reputation of yourself and others? Is your behavior honest and legal?*

Bring Your Own Device Program

Maumee City Schools is committed to utilizing powerful online productivity tools and resources to enhance learning opportunities for our students. As part of this commitment, the district is allowing students in grades PK-12 and staff to bring their personally owned wireless electronic devices to school for the purpose of completing school work through the school's filtered wireless network. With staff approval, students will be able to access the school's filtered Internet connection and online resources (Google Apps, etc.) to complete their schoolwork. We realize that not every student owns a device; and for those who do, some may choose not to bring their personally owned device to school. There is absolutely no expectation that parents should provide a device to their child for this program.

Approved Devices

For the purpose of this “BYOD” program, approved devices include any privately owned wireless communication device that:

- A. Accesses the Internet through a fully functional web browser
- B. Has the capability to access the school’s wireless network
- C. Has the capability to complete and submit schoolwork

Approved devices include, but are not limited to: laptops, netbooks, tablets, eReaders, and smartphones. Students should ask for clarification on devices not listed.

Approved Use

All use of the devices while on school campuses and on the district’s network must be for the sole purpose of schoolwork. Non-instructional activities are not permitted. Use of school network or services for entertainment or social purposes is prohibited. Use of school network resources for political, religious, or commercial purposes is strictly forbidden. However, personal cell phone calls or text messages outside of school hours are permitted.

Approved Access

When using personal devices at school, students will only be permitted to access the Internet through the Maumee City Schools wireless network. This is the same filtered Internet connection that all school computers use and should not be circumvented in accordance with the Children’s Internet Protection Act. Students may not use their device as a “hot spot” to allow other students to access the internet during the school day. Users should use school provided or approved web-based resources (i.e., Google Apps, etc.) for completing and submitting schoolwork. Personal devices will not have access to school internal resources or servers.

APPROVED PLACES AND TIMES

TIME OF DEVICE USE	HS	MS	ELEM
Classrooms	Staff Discretion		
School sponsored extra-curricular activities	Staff Discretion		
School buses or other transport	Staff Discretion		
Cafeteria / Breakfast, Lunch	Yes	Staff Discretion	Staff Discretion
Hallways / Class Change or Hall Pass	Yes	No	No
Restrooms, Locker Rooms, Changing Rooms	No	No	No
During State Assessments	No	No	No

CELL PHONES, IPODS, MP 3 PLAYERS, CD PLAYERS, AND WIRELESS COMMUNICATION DEVICES

Cell Phones, portable radios, Mp3 players, iPods, CD’s, laser pens, lights, and other electronic entertainment equipment should not be used or visible during classroom time unless use is permitted by the teacher for educational purposes. Use of this equipment in the halls, cafeteria, school buses, locker rooms/rest rooms, or during state assessments is addressed in the Technology and Acceptable Use Policy.

Any electronic device confiscated for inappropriate use will be returned to the student at the end of the day and will result in a three demerit penalty. Second and or subsequent offenses will result in the electronic device being returned at the end of the school year, or may be picked up by the student’s parent and will result in six demerits.

Possession of a cell phone or other electronic communications device by a student is a privilege which may be forfeited by the student if he/she violates this policy. Students who bring these devices to school are responsible for the security of these devices. The Maumee City Schools are not responsible theft, damage, loss., or vandalism to a student electronic device or any other student property. Devices may not be used to take pictures, videos, or voice recordings without teacher and administrative approval.

SEXTING

Any student transmitting or being in possession of any material considered to be harmful to a juvenile or representing nudity, sexual conduct, sexual excitement or sado-masochistic abuse (as cited in RC sect. 2907.01) may be subject to suspension with a recommendation for expulsion. By Ohio law, local law enforcement officials and/or Children Protective Officials may be notified of any such activity if discovered by school officials.

PHOTOGRAPHS/VIDEO/VOICE RECORDINGS

Photographs, video, and voice recordings may not be taken at any time without the permission of the classroom teacher and the administration. This includes the use of personal cameras, cell phones, etc. Equipment owned by the school district may be used in classes and activities at the discretion of the teacher or advisor.

MAUMEE CITY SCHOOLS TRANSPORTATION POLICY

BUS TRANSPORTATION

Transportation to and from Maumee High School is offered to those students living farther than one mile from the school. For complete information concerning bussing, please call the Maumee City Schools' Transportation Office at 419-893-1392.

STUDENT RESPONSIBILITIES

Positively no smoking, producing an open flame, usage of drugs or alcohol is allowed on a bus. The use of cell phones is prohibited while on the bus. Students shall enter and leave a school bus in an orderly manner. They shall take their seats quickly and quietly. Seats may be assigned by the bus driver to maintain order. All students will be seated while the bus is in motion. Noise shall be kept at a minimum at all times. No talking at railroad crossings and other places of danger, as specified by the driver. Reasonable visiting and conversation are permissible. No vulgar language is allowed. Students will ride their assigned busses to and from school and get on and off at their assigned stops. If a student rides a bus other than the assigned bus, he/she shall have a note from his/her parents and signed by the principal. The Superintendent or designee may, at his/her discretion, approve temporary transportation. Approval must be in writing stating the length of time the student (s) is eligible for transportation. Students shall not hang objects or parts of their bodies outside the bus windows or doors, open windows or doors without permission of the driver, throw any object out of or inside the bus, litter and/or eat inside the bus.

FORBIDDEN CARGO

While students are riding on the bus, animals, firearms, ammunition, explosives, aerosol sprays or other dangerous materials or objects which may interfere with the safe operation of the vehicle shall not be transported. Class projects and /or musical instruments must be stored in accordance with instructions from the driver, subject to approval of the Supervisor of Transportation. Parents are responsible for any damage to a school bus caused by their students. (This also applies to private or public property while students are at a school bus stop). The driver on a regular bus run shall be in full charge of the bus at all times and shall be responsible for order and the safety of the students on the bus. Any teacher, while accompanying a class on a field trip, is responsible for the discipline and control of behavior of the students. The refusal of the student to give a correct name to a bus driver or the proper authorities is considered to be a serious violation, and the student will be referred to the building principal for disciplinary action. Disorderly conduct, or refusal to submit to the authority of the driver shall be sufficient reasons for school principals to refuse transportation service to any student. School principals shall notify the parents in writing of such refusal.

The Maumee Board of Education transports students to the high school who live more than one mile from the school. This is a service provided by the Board, not required by the State Department.

STUDENT DRIVING

All vehicles may be subject to random search while on school property.

Students may drive autos, motorbikes, or motorcycles to school providing the following regulations are followed:

1. The speed limit on school property is posted at 5 mph.
2. The driveway in front of the school is a one-way street at all times.
3. Students must register any vehicle they intend to drive to school and leave in the school parking lot. The registration can be completed in the front office. Students will be issued a hanging parking permit that must be displayed in the front windshield of the auto.
4. Cars must be parked properly. Any vehicles parked in fire lanes will be ticketed by the Maumee Police Department and could be towed.

5. Autos must also not be parked in truck delivery areas near the cafeteria. Students who violate driving regulations or fail to register their vehicles are subject to the following actions:
- a) Demerits
 - b) Traffic fines, parking tickets, unauthorized use of vehicle fines. Fines range from \$1.00 to \$10.00 depending on the number of violations.
 - c) Repeat violators or students who drive recklessly on property will have their driving privileges revoked.
 - d) Illegally parked vehicles will be towed, at cost to the student, if necessary.
 - e) Parking is at the owner's risk. Full-time supervision is not provided.
 - f) Students are not permitted in the parking areas or in their vehicles during the school day unless they have received an off-campus leave pass from the front office.

Students are to park in the white spaces designated for student parking. Students parking in yellow, teacher designated spaces may be subject to fines, demerits, and/or loss of privilege.

CO-CURRICULAR DRUG TESTING POLICY

(BOARD POLICY 5530.01)

Maumee City Schools provides a variety of co-curricular activities that complement the educational and athletic development of each student. In exchange for the privilege of participating in these activities student participants are responsible for adhering to the Athletic/Extra-Curricular/Co-Curricular Activity Code of Conduct (hereinafter "Code of Conduct") and to this policy. Participants in athletic, extra-curricular and co-curricular activities (hereinafter "student participants") agree to represent Maumee City Schools in a positive manner, to conduct themselves in a manner that is acceptable to coaches, advisors and the school community and to present a positive role model for other students and children in the community. The Code of Conduct applies to student participants at all times, not only when they are at school or participating in activities.

The scope of application, in short, is limited to those students who participate in athletic programs, extracurricular and/or co-curricular activities that have a competition aspect, voluntary opt-in participants, as well as those who apply for or hold a parking permit at Maumee High School.

As part of the online back-to-school form parents will complete this summer, parents will be presented with an "informed consent" form. With this form parents can (a) consent for their student to be part of the random drug testing pool - allowing them to participate in any athletic program, and/or selected competitive extracurricular or co-curricular programs, or apply for a parking permit, (b) opt their student into the random drug testing pool regardless of activity participation, or (c) not sign the form to consent for their student to be part of the random drug testing pool with the understanding that this will result in the student not being able to participate in any athletic program, and/or selected competitive extracurricular or co-curricular programs, or apply for a parking permit.

Starting in the fall, students will be randomly selected from the pool of eligible students by the testing company. Those students will be processed by the screening company here in our schools. If the results of the test come back "non-negative", the testing company will contact the parents and ask for additional information related to medications or other factors that might have contributed to a non-negative result. If the result is "positive" as verified by the company's certified laboratory, the parent and a school official will be contacted. There are no academic consequences for a positive result, but there are consequences as outlined in the Athletic/Extracurricular/C-curricular Activity Code of Conduct. The student will immediately be referred to an intervention/treatment program.

STUDENT ACTIVITIES

ASSEMBLIES

Respect for guests and students is expected at all times. Noncompliance to reasonable directions places a student in jeopardy for school discipline and possible prohibition from future assemblies.

Students who continually do not follow reasonable directions or commands by school employees (aside from assemblies) may also be prohibited from attending assemblies.

Students are required to sit with their grade level teacher at all assemblies except for pep assemblies.

GOOD SPORTSMANSHIP

Maumee High School actively promotes good sportsmanship at all extra-curricular events. The Assistant Commissioner and Chairman of the Sportsmanship, Ethics and Integrity committee for OHSSA states, Good sportsmanship is the attitude and behavior that exemplifies positive support for the interscholastic athletic programs. Furthermore, the official OHSAA sportsmanship rules include the following:

1. Realizing that athletics are part of the educational experience, and the benefits of involvement go beyond the final score of a game;
2. Participating in positive cheers that encourage our athletes; and discouraging any cheers that would redirect that focus-including those that taunt and intimidate opponents, their fans and officials;
3. Learning, understanding, and respecting the rules of the game, the officials who administer them and their decisions;
4. Respecting our opponents as fellow students, and acknowledging them for striving to do their best; and
5. Developing a sense of dignity under all circumstances.

In those same guidelines, OHSAA identifies “integrity, fairness, and respect as the principles of good sportsmanship, and with them, the spirit of competition thrives. Fueled by honest rivalry, courteous relations and graceful acceptance of the results”. The OHSSA also recognizes that a total team effort by all aspects for the community is needed to create sportsmanship as a number one priority. They indicate student groups and fans should demonstrate the following characteristics:

1. Stimulate desired crowd response using only positive cheers, signs and praise without antagonizing or demeaning opponents.
2. Treat opposing spirit groups and fans with respect.
3. Recognize outstanding performances on either side of the playing field or court.
4. Know rules and strategies of the contest in order to cheer at proper times.
5. Maintain enthusiasm and composure, serving as a role model.
6. Restrain from charging the playing area during or following a contest.

Lastly, our board of education and administration expects that our student and adult fans involved in extra-curricular activities demonstrate the same level of responsibility and behavior at practice and competitions as is expected in the classroom. Thus, we feel our rationale for promoting positive behavior, cheers and chants is founded on the principles outlined in our state athletic association guidelines and is worthy of our time and effort.

Please note: Failure to follow these guidelines may result in disciplinary action and/or eviction from the event (either home or away) with no refund of admittance fee. Removed students must immediately leave the venue property and are responsible for contacting parents for transportation home, if necessary.

GUIDELINES FOR SCHOOL DANCES

All dances are considered to be school functions. Relevant school rules will be in effect during dances. Rules specific to dances are spelled out in the “Maumee High School Sponsored Dance Contract”. A student and parent signed contract must be filled out on the Parent Portal in order for the student to purchase a ticket or attend a school dance. Chaperones reserve the right to deny entry to any student determined to be in violation of the dance rules and/or remove students from the premises.

USE OF MEDICATIONS

The Maumee City School District will consider the diagnosis and treatment of illnesses and the prescription of all drugs, medications, preparations, and/or remedies as the direct responsibility of the parent and/or physicians of their choice.

The total responsibility for dispensing or administering any non-prescribed (over-the-counter) drugs, preparations, and/or remedies shall rest solely with the parent or legal guardian, and the student. School personnel will, under no circumstances, dispense or administer such non-prescribed (over-the-counter) medications to any student.

Before any prescribed medication or treatment may be administered to any student during school hours, the Board shall require the written prescription from the child’s physician along with the written authorization of the parent. This document shall be kept on file in the office of the principal.

For purpose of this policy, "medication" shall include all medicines including those prescribed by a licensed health professional authorized to prescribe drugs and any non-prescribed (over-the-counter) drugs, preparations, and/or remedies. "Treatment" refers both to the manner in which a medication is administered and to health-care procedures that require special training, such as catheterization.

When a student is ill to the extent that over-the-counter medication is required during the school day, parents or legal guardians should consider keeping that student home until the need for medication is gone.

If there continues to be a need for non-prescribed medication while the child is at school, Form 5330F1a, (Authorization for Nonprescribed Medication or Treatment) shall be completed and turned in to the school office before use of the non-prescribed medication at school.

Students at the middle and high school may carry these non-prescribed medications during the school day along with a copy of Form 5330F 1a. Students in elementary schools shall not be allowed to carry non-prescribed medications.

No student allowed providing or selling any type of medication, prescribed or non-prescribed medication to another student. Violations of this rule will be considered violations of Policy 5530- Drug Prevention and the Student Code of Conduct/Discipline Code.

Only medication in its original container, labeled with the date, if a prescription; the student's name, exact dosage will be administered. The Superintendent shall determine a location in each building where the medications to be administered under this policy shall be stored, which shall be in a locked storage place, unless the medications require refrigeration in which case they shall be stored in a refrigerator in a place not commonly used by students.

However, students shall be permitted to carry and use, as necessary, an asthma inhaler, provided the student has prior written permission from his/her parent and physician and has submitted Form 5330F3, Authorization for the possession and Use of Asthma Inhaler.

Additionally, students shall be permitted to carry and use, as necessary, an epinephrine autoinjector to treat anaphylaxis, provided the student has written approval from the physician and their parent. Form 5330F4, Allergy Action Plan, shall be completed by the student's physician and parent and submitted to building principal. The parent/guardian of the student shall provide a back-up dose of the medication to the principal or school nurse. Permission to carry an epinephrine autoinjector shall extend to any activity, event, or program sponsored by the school or in which the school participates. In the event that the epinephrine autoinjection is administered by the student or school employee at school or at any covered events, a school employee shall immediately request assistance from an emergency medical service provider (911).

The following staff is designated as being authorized to administer medication and treatment to students:

1. principal
2. teacher
3. school nurse
4. building secretary
5. aide
6. others as designated by student's IEP and/or 504 plan

No employee will be required to administer a drug to a student if the employee objects, on the basis of religious convictions, to administering the drug.

Additionally the Board shall permit the administration by a licensed nurse or other authorized staff member of any medication requiring intravenous or intramuscular injection or the insertion of a device into the body when both the medication and the procedure are prescribed by the student's physician and written consent of student's parent.

MAUMEE HIGH SCHOOL ATHLETICS, EXTRA-CURRICULAR, &

CO-CURRICULAR ACTIVITY GUIDE

Wondering what extra-curriculars you can be a part of at Maumee High School?
The following activities are available for participation.

INTERSCHOLASTIC SPORTS

FALL

Cheerleading
Cross Country (B/G)
Football
Golf (B/G)
Soccer (B/G)
Tennis - Girls
Volleyball

WINTER

Basketball (B/G)
Bowling (B/G)
Cheerleading
Gymnastics
Ice Hockey
Swimming/Diving
Wrestling

SPRING

Baseball
Softball
Tennis - Boys
Track (B/G)

MUSIC AND DRAMA

Choir
Band
Color Guard

Orchestra
Drumline
Winter Guard

Musical (performance, tech, stage crew)
Fall Play (performance, tech, stage crew)
Winter Play (perform, tech, stage crew)

CLUBS AND ACTIVITIES

Speech and Debate Team
Drama Club
French Club
Rotary Interact Club
He for She
World Explorers Club
Programming Club
Young Politicians Club

Quiz Bowl
Student Council
German Club
J.E.T.S. Engineering / Physics Club
Leadership Club
Fellowship of Christian Athletes
FCCLA
Dance Team

Technology Club
Chemistry Club
Spanish Club
D.E.C.A.
Astronomy Club
Book Club
Art Club

The Board of Education will set a **Student Activity Fee** for all sport teams, clubs, music programs, and/or extra curricular programs. The fees are payable to the coach, advisor or director prior to the first activity, game or event. Checks should be made payable to Maumee High School with a notation of **activity fee**. Students pay only once for the entire school year, no matter how many activities or sports in which they participate. Families with multiple students may have the rate adjusted.

MAUMEE ATHLETICS

The Maumee City Schools, coaches, administrators, and teachers are proud of the athletic program that is offered to our students. Being a part of that program is an honor. We hope that the student athlete and coaching staff will strive for both athletic excellence as well as academic excellence.

The following serves as the Philosophy of Participation in athletics in the Maumee City Schools.

1. It is an honor and privilege to represent Maumee as a participant in inter-scholastic athletics. It is, however, in no way a vested right of any student.
2. Athletes are expected to be responsible and self-disciplined. It is consistent with the definition of athletic endeavor that they be so.
3. Self-image, character and social skills can be enhanced on a personal level through participation in athletics.
4. The athlete will be a role model, especially for younger students.
5. Athletes should be aware of peer pressure and their ability to serve a "positive peers".

To insure both the student athlete and his/her parents understand what is expected of him/her, a written copy of the rules commonly called the Code of Conduct established by the Maumee Athletic/Activities Department and approved by the Maumee Board of Education will be provided.

An informational meeting for parent(s)/guardian(s) and student-athletes will be held prior to each sports season where the Code of Conduct will be distributed. Non-attendance at this meeting and/or failure to return the signed statement that indicates understanding of the Code of Conduct shall not excuse participants from abiding by its policies and procedures.

Furthermore, the MHS Parent-Student Handbook for Athletics and Activities will be issued to each student at the beginning of each sports season. This handbook outlines the rules, procedures, and expectations for all participants in the MHS athletic program, including parental involvement with the student-athlete and expectations of fan behavior.

ATHLETIC ELIGIBILITY

The Maumee City Schools are members of the Ohio High School Athletic Association (www.ohsaa.org). They are in good standing and abide by the rules of the Association. The following essential eligibility requirements are only some of the regulations affecting student eligibility. All requirements are published in the OHSAA Handbook, which can be found in the offices of the principal and athletic/activities director and is posted on the OHSAA web site.

Scholarship – Do not change your course schedule without first consulting with the athletic administrator or guidance counselor to determine whether it will affect your eligibility. Eligibility for each grading period is determined by grades received the preceding grading period. You must be currently enrolled in school and passing a minimum of five one credit courses or the equivalent, and receiving a minimum 1.5 GPA and no more than one "F" in the preceding grading period. Summer school grades may not be used to substitute for failing grades received the final grading period of the regular school year. Note: For the trimester schedule, a student must pass any four of five classes scheduled and maintain the necessary 1.5 GPA. PSO students must enroll and maintain the five credit equivalent, whether enrolled full-time PSO or in combination w/high school coursework, and maintain a 1.5 GPA.

Changing Schools-Transfers - If a student transfers (changes) high schools at any time after establishing eligibility as a ninth grader (either by attending a school for five days or playing in a fall sport prior to the beginning of school), the student is ineligible at the new high school for the first fifty percent (50%) of the maximum allowable regular season contests in those sports in which the student participated during the twelve (12) months immediately preceding the transfer. The OHSAA currently has several exceptions to this bylaw; please consult the athletic/activities director to see if you qualify.

Non-Interscholastic Competition – You are advised to consult with your school principal or athletic administrator prior to any such participation. You may not try out, practice or participate in a contest with a non-school team while a member of a school team in the same sport. For a more detailed explanation, visit www.ohsaa.org or consult the Student-Athlete/Parent Handbook.

Sports Camps/Instructional Programs – You may attend camps, clinics and workshops that involve team play any time between June 1 and July 31. Team play means there is more than one player opposing one player. There is no limit on the number of students from the same school team that may participate on the same non-school team from June 1 to July 31. You may receive instruction from a coach from a school team only:

1. During the season of the sport, or
2. For 10 days only from June 1 to July 31.

There are several exceptions to this bylaw. For a more detailed explanation, visit www.ohsaa.org or consult the athletic/activities director.

MAUMEE CITY SCHOOLS ATHLETIC/ EXTRACURRICULAR/ CO-CURRICULAR ACTIVITY CODE OF CONDUCT

This code of conduct applies to all athletic, extracurricular, co-curricular and other out-of-class activities sponsored by Maumee High School or Gateway Middle School, including, but not limited to, clubs, student council, class organizations, athletic programs, academic competitions, honor and awards programs, intramurals, drama, music events and performances.

Student participation in activities is a privilege granted by Maumee City Schools, not a vested right. In exchange for this privilege, student participants accept an obligation to represent their school in a positive manner, an obligation to conduct themselves in a manner that is acceptable to their coaches, their advisors and the school community and an obligation to present a positive role model for other students and the young children of our community. Students who do not honor their obligations may have their participation privilege withdrawn.

This code is in effect twenty-four hours a day, seven days a week, twelve months a year.

PROHIBITED CONDUCT

CONDUCT UNBECOMING

Students exhibiting behavior deemed conduct unbecoming a Maumee High School or Gateway Middle School student in any location at any time will be subject to participation privilege withdrawal. Conduct unbecoming includes any conduct which is a violation of the student discipline section of the Maumee High School handbook (applied both during and outside the school year) or a violation of the school rules section of the Gateway Middle School handbook (applied both during and outside the school year) or which is found to be a probable violation of federal, state or local criminal or juvenile law.

Conduct unbecoming also includes conduct that violates the expectations for use of social media included in the Student-Athlete/Parent Handbook. The Maumee City Schools will investigate suspected or reported violations by members of athletic, extracurricular and co-curricular programs of the social media expectations outlined in the Student-Athlete/Parent Handbook. Participants who violate stated expectations are subject to participation privilege withdrawal and, where appropriate, referral to law enforcement authorities.

A student who attends a party or gathering where any prescription drug (without the lawful prescription holder), alcoholic beverage, illegal drug, non-prescription drug (for non-medical use), counterfeit drug, tobacco or tobacco product is present and who does not leave as soon as is reasonably and safely possible will be subject to participation privilege withdrawal for conduct unbecoming. A student present in a restaurant, theater, banquet hall, stadium or other public place during normal business hours or normal activities is not participating in a proscribed party or gathering. A student attending a family reunion, wedding reception, holiday celebration, graduation party, birthday party or similar function that is not primarily a party for or a gathering of middle school or high school students, college students or college-age non-students is not attending a proscribed party or gathering.

ALCOHOL/DRUGS/TOBACCO

A student, who possesses or conceals any prescription drug (without a lawful prescription), alcoholic beverage, illegal drug, non-prescription drug (for non-medical use), counterfeit drug, tobacco or tobacco product and/or related paraphernalia; who consumes or shows evidence of consumption of, any prescription drug (without a lawful prescription) or non-prescription drug (for non-medical use), counterfeit drug, tobacco or tobacco product and/or related paraphernalia; or who transfers or offers for sale any prescription drug, alcoholic beverage, illegal drug, non-prescription drug, counterfeit drug, tobacco or tobacco product and/or related paraphernalia, will be subject to participation privilege withdrawal.

PARTICIPATION PRIVILEGE WITHDRAWAL

CONDUCT UNBECOMING

First Violation. The first time a student is found to have engaged in conduct unbecoming, the student will receive a written reprimand and the student may be denied the privilege of participating in interscholastic athletic competitions for up to the equivalent of 20% of an athletic season and may be denied the privilege of participating in extracurricular, co-curricular and other out-of-class activities (not including tryouts or auditions for future activities) for up to 30 calendar days (such calendar days to include only days for which school is in session).

Second Violation. The second time a student is found to have engaged in conduct unbecoming, the student will receive a written reprimand, the student will be denied the privilege of participating in interscholastic athletic competitions for the equivalent of one athletic season and the student will be denied the privilege of participating in extracurricular, co-curricular and other out-of-class activities (not including tryouts or auditions for future activities) for a period of 60 calendar days (such calendar days to include only days for which school is in session).

Third Violation. The third time a student is found to have engaged in conduct unbecoming, the student will receive a written reprimand and the student will be denied the privilege of participating in athletic,

extracurricular, co-curricular and other out-of-class activities (not including tryouts or auditions for future activities) for a period of 12 consecutive months.

Fourth Violation. The fourth time a student is found to have engaged in conduct unbecoming, the student will receive a written reprimand and the student will be denied the privilege of participating in athletic, extracurricular, co-curricular and other out-of-class activities while attending Maumee City Schools.

Counting Violations. A prior alcohol, drug, tobacco violation will be counted as a conduct unbecoming violation in determining a student's cumulative conduct unbecoming violations.

ALCOHOL/DRUGS/TOBACCO

First Violation. The first time a student is found to have engaged in conduct involving alcohol, drugs or tobacco the student will receive a written reprimand, the student will be denied the privilege of participating in athletic activities for the equivalent of one athletic season and will be denied the privilege of participating in extracurricular, co-curricular and other out-of-class activities (not including tryouts or auditions for future activities) for a period of 60 calendar days (such calendar days to include only days for which school is in session).

Second Violation. The second time a student is found to have engaged in conduct involving alcohol, drugs or tobacco the student will receive a written reprimand and the student will be denied the privilege of participating in athletic, extracurricular, co-curricular and other out-of-class activities (not including tryouts or auditions for future activities) for a period of 12 consecutive months.

Third Violation. The third time a student is found to have engaged in conduct involving alcohol, drugs or tobacco the student will receive a written reprimand and the student will be denied the privilege of participating in athletic, extracurricular, co-curricular and other out-of-class activities while attending Maumee City Schools.

Counting Violations. A prior conduct unbecoming violation will not be counted as an alcohol, drug, tobacco violation in determining a student's cumulative alcohol, drug, tobacco violations.

FINDING OF PROHIBITED CONDUCT

DETERMINATION OF PRIVILEGE WITHDRAWAL

The Athletic/Activities Director for the school attended by the student will make all findings with respect to a student having engaged in conduct unbecoming or a student having engaged in conduct involving alcohol, drugs or tobacco. The withdrawal of a participation privilege will begin upon the Athletic/Activities Director's determination there is reasonable cause to believe the student engaged in prohibited conduct. Upon determining there is reasonable cause to believe the student engaged in prohibited conduct, the Athletic/Activities Director will meet with the student to inform the student of the withdrawal of participation privilege or, in the case of a conduct unbecoming first violation, the potential withdrawal of the student's participation privilege. Upon the Athletic/Activities Director's determining that the student did engage in prohibited conduct, the Athletic/Activities Director will meet with the student to issue the written reprimand and to confirm to the student continued withdrawal, if any, of the student's participation privilege.

The Athletic/Activities Director for the school attended by the student in consultation with the Principal of the school attended by the student will determine whether and to what extent a student found for the first time to have engaged in conduct unbecoming will be subject to a period of participation privilege withdrawal. For a first time conduct unbecoming violation the participation privilege withdrawal period, if any, may be, but shall not exceed, nonparticipation in interscholastic athletic competitions for the equivalent of a portion of 20% of an athletic season and nonparticipation in extracurricular, co-curricular and other out-of class activities (not including tryouts or auditions for future activities) for 30 calendar days (such calendar days to include only days for which school is in session).

For all second, third and fourth conduct unbecoming violations and for all alcohol, drug, tobacco violations, the Athletic/Activities Director will impose the participation privilege withdrawal period stated in this code.

APPEAL OF FINDING OF PROHIBITED CONDUCT

A student found by the Athletic/Activities Director to have committed a violation of this code may appeal the Athletic/Activities Director's finding of a violation to an Appeal Panel by submitting a written request for a review to the Principal of the school attended by the student within 30 calendar days after receiving a written reprimand from the Athletic/Activities Director. If the student does not timely file a written request for review with the Principal of the school attended by the student, the student will forfeit the opportunity for review by an Appeal Panel.

The members of the Appeal Panel will be the Principal of the school attended by the student, a faculty or staff member or volunteer coach or advisor selected by the student and a Community Representative selected by the Superintendent, who will serve as the three voting members, and the Athletic/Activities Director for the school attended by the student, who will serve as a non-voting member. If the student fails to select a faculty or staff member or volunteer coach or advisor for the Appeal Panel, the vacancy will be filled with the student assistance counselor. For students with an individual education plan, the Director of Student Services will serve on the Appeal Panel in the place of the Principal of the school attended by the student.

The Appeal Panel will review the Athletic/Activities Director's findings, will meet with the student, and may in its discretion, conduct further proceedings. At the student's election, the student may appear before the Appeal Panel with or without a representative and with or without a parent or legal guardian. The proceedings of the Appeal Panel will be informal, will not be subject to any rules of evidence, procedure or due process and will not be recorded.

The Appeal Panel may confirm the Athletic/Activities Director's finding of a violation, may find there was no violation, or may find that there was a violation of a lesser severity or of a different category than found by the Athletic/Activities Director. If the Appeal Panel finds no violation or a violation of a lesser severity or of a different category, the Appeal Panel will adjust the withdrawal of participation privilege period to fit the finding. A decision of the Appeal Panel will be made by simple majority vote of the three voting members.

The withdrawal of the student's participation privilege that began upon the Athletic/Activities Director's determination there was reasonable cause to believe the student engaged in prohibited conduct will continue during the student's appeal to the Appeal Panel.

REDUCTION OF THE PERIOD OF WITHDRAWAL

First Conduct Unbecoming Violation. A student may request a reduction of a privilege withdrawal period for a first conduct unbecoming violation by submitting a written request for reduction to the Principal of the school attended by the student at any time during the privilege withdrawal period. The Principal will forward the written request to the Review Panel.

The Review Panel will review the Athletic/Activities Director's determination of the privilege withdrawal period, will meet with the student, and may in its discretion conduct further proceedings. At the student's election the student may appear before the Review Panel with or without a representative and with or without a parent or legal guardian. The proceedings of the Review Panel will be informal, will not be subject to any rules of evidence, procedure or due process and will not be recorded.

The Review Panel may confirm the Athletic/Activities Director's determination of the privilege withdrawal period, may reduce the privilege withdrawal period on the condition of the performance of tasks by the student, or may reduce the privilege withdrawal period without condition.

Second Conduct Unbecoming Violation. A student may request a reduction of a privilege withdrawal period for a second conduct unbecoming violation by submitting a written request for reduction to the Principal of the school attended by the student at any time during the privilege withdrawal period. The Principal will forward the written request to the Review Panel.

The Review Panel will review the Athletic/Activities Director's determination of the privilege withdrawal period, will meet with the student, and may in its discretion conduct further proceedings. At the student's election the student may appear before the Review Panel with or without a representative and with or without a parent or legal guardian. The proceedings of the Review Panel will be informal, will not be subject to any rules of evidence, procedure or due process and will not be recorded.

The Review Panel may confirm the Athletic/Activities Director's determination of the privilege withdrawal period, may reduce the privilege withdrawal period on the condition of the performance of tasks by the student, or may reduce the privilege withdrawal period without condition, subject to the limitation that the Review Panel may not reduce the privilege withdrawal period to less than nonparticipation in interscholastic athletic competitions for the equivalent of 20% of an athletic season and nonparticipation in extracurricular, co-curricular and other out-of-class activities (not including tryouts or auditions for future activities) for 30 calendar days (such calendar days to include only days for which school is in session).

Third Conduct Unbecoming Violation. A student may request a reduction of a privilege withdrawal period for a third conduct unbecoming violation by submitting a written request for reduction to the Principal of the school attended by the student at any time during the privilege withdrawal period. The Principal will forward the written request to the Review Panel.

The Review Panel will review the Athletic/Activities Director's determination of the privilege withdrawal period and will meet with the student and the student's parent(s) or legal guardian. The student and parent(s) or legal guardians will present to the Review Panel a written program of tasks to be completed by the student before any reduction in the privilege withdrawal period. The tasks should include education, assessment or community service intended to meet the objectives of reinforcing to the student the improper nature of the student's conduct and providing experience through which the student may learn the distinction between proper and improper conduct and the potential consequences of improper conduct. It is the responsibility of the student and the student's parent(s) or legal guardian (1) to persuade the Review Panel that the program will be meaningful and will direct the student to these objectives and (2) to secure a faculty member, coach or advisor to act as case manager for the student. The Review Panel will determine whether the proposed program is, in the opinion of the Review Panel, sufficient to justify a reduction in the privilege withdrawal period. If the Panel determines the proposed program is not sufficient to justify a reduction in the period of the participation privilege withdrawal, the student and the student's parent(s) or legal guardian will be allowed one second meeting to submit an improved proposed program to the Review Panel.

When the student completes all tasks included in the approved program, the student, the student's parent(s) or legal guardian and the student's case manager will meet with the Review Panel to present verification of the student's completion of the program tasks. If the Review Panel is satisfied the student completed the program tasks, has an understanding of the improper nature of the student's conduct and is adequately aware of the distinction between proper and improper behavior and the potential consequences of improper behavior, the Review Panel may reduce the privilege withdrawal period, subject to the limitation that the Review Panel may not reduce the privilege withdrawal period to less than nonparticipation in interscholastic athletic competitions for the equivalent of one full athletic season and nonparticipation in extracurricular, co-curricular and other out-of-class activities (not including tryouts or auditions for future activities) for 90 calendar days (such calendar days to include only days for which school is in session).

Fourth Conduct Unbecoming Violation. No appeal for a fourth conduct unbecoming violation will be allowed. The privilege withdrawal period for a fourth conduct unbecoming violation will be served in full. The student will be denied the privilege of participating in athletic, extracurricular, co-curricular and other out-of-class activities while attending Maumee City Schools.

First Alcohol, Drug, Tobacco Violation. A student may request a reduction of a privilege withdrawal period for a first alcohol, drug, tobacco violation by submitting a written request for reduction to the Principal of the school attended by the student at any time during the privilege withdrawal period. The request must include a consent signed by the student and the student's parent(s) or legal guardian for the disclosure and release of information then known or later acquired by the student assistance counselor through intervention or in counseling. The Principal will forward the written request to the Review Panel and the signed disclosure and release to the student assistance counselor.

The Athletic/Activities Director will meet with the student and the student's parent(s) or legal guardians to inform them of the tasks or programs the Athletic/Activities Director determined the student must complete or meaningfully participate in during the original privilege withdrawal period to be considered for a reduction in the privilege withdrawal period. Such tasks and programs may include (1) special classes or assignments in drug, alcohol or tobacco education, community service or citizenship education; (2) participation in school or community groups, (3) assessments and possible treatment for alcohol, drug or tobacco dependence, or (4) completion of a written report on the detrimental physical and mental effects of alcohol, drugs and tobacco. The cost of such tasks and programs will be paid by the student or the student's parent(s). Upon completion of (or on meaningful participation in) the assigned tasks or programs, the student may submit a written request that the student's privilege withdrawal period be reduced to time served to date. The Athletic/Activities Director will forward the student's request to the Review Panel and present to the other members of the Review Panel a written or oral report on the programs and tasks assigned the student, the student's progress on such programs and tasks and a recommendation on the student's privilege withdrawal period.

The Review Panel may confirm the Athletic/Activities Director's recommendation on the privilege withdrawal period, may reduce the privilege withdrawal period from the original period on the condition of the performance of additional tasks or participation in additional programs, or may reduce the privilege withdrawal period from the original period without condition, subject to the limitation that the privilege withdrawal period may not be reduced to less than nonparticipation in interscholastic athletic competitions for the equivalent of 20% of an athletic season and nonparticipation in extracurricular, co-curricular and other out-of class activities (not including tryouts or auditions for future activities) for 30 calendar days (such calendar days to include only days for which school is in session).

Second Alcohol, Drug, Tobacco Violation. A student may request a reduction of the privilege withdrawal period for a second alcohol, drug, tobacco violation by submitting a written request for reduction to the Principal of the school attended by the student at any time during the privilege withdrawal period. The request must include a consent signed by the student and the student's parent(s) or legal guardian for the disclosure and release of information then known or later acquired by the student assistance counselor through intervention or in counseling. The Principal will forward the written request to the Review Panel and the signed disclosure and release to the student assistance counselor.

The Review Panel will review the Athletic/Activities Director's determination of the privilege withdrawal period and will meet with the student and the student's parent(s) or legal guardian. The student and parent(s) or legal guardians will present to the Review Panel a written program of tasks to be completed by the student before any reduction in the privilege withdrawal period. The tasks should include education, assessment or community service intended to meet the objectives of reinforcing to the student the improper nature of the student's conduct and providing experience through which the student may learn the distinction between proper and improper conduct and the potential consequences of improper conduct. It is the responsibility of the student and the student's parent(s) or legal guardian (1) to persuade the Review Panel that the program will be meaningful and will direct the student to these objectives and (2) to secure a faculty member, coach or advisor to act as case manager for the student. The Review Panel will determine whether the proposed program is, in the opinion of the Review Panel, sufficient to justify a reduction in the privilege withdrawal period. If the Panel determines the proposed program is not sufficient to justify a reduction in the privilege withdrawal period, the student and the student's parent(s) or legal guardian will be allowed one second meeting to submit an improved proposed program to the Review Panel.

When the student completes all tasks included in the approved program, the student, the student's parent(s) or legal guardian and the student's case manager will meet with the Review Panel to present verification of the student's completion of the program tasks. If the Review Panel is satisfied the student completed the program tasks, has an understanding of the improper nature of the student's conduct and is adequately aware of the distinction between proper and improper behavior and the potential consequences of improper behavior, the Review Panel may reduce the privilege withdrawal period, subject to the limitation that the Review Panel may not reduce the privilege withdrawal period to less than nonparticipation in interscholastic athletic competitions for the equivalent of one full athletic season and nonparticipation in extracurricular, co-curricular and other out-of class activities (not including tryouts or auditions for future activities) for 90 calendar days (such calendar days to include only days for which school is in session).

Third Drug, Alcohol, Tobacco Violation. No appeal for a third drug, alcohol, tobacco violation will be allowed. The privilege withdrawal period for the third drug, alcohol, tobacco violation will be served in full. The student will be denied the privilege of participating in athletic, extracurricular, co-curricular and other out-of-class activities while attending Maumee City Schools.

The Review Panel. The members of the Review Panel will be the Principal of the school attended by the student, the student assistance counselor, a guidance counselor at the school attended by the student, a faculty or staff member or volunteer coach or advisor selected by the student and a Community Representative selected by the Superintendent, who will serve as the five voting members, and the Athletic/Activities Director for the school attended by the student, who will serve as a non-voting member. For students with an individual education plan, the Director of Student Services will serve on the Review Panel in the place of the guidance counselor at the school attended by the student. If the student fails to select a faculty or staff member or volunteer coach or advisor for the Review Panel, the vacancy will be filled with a faculty or staff member or volunteer coach or advisor selected by the Principal. The proceedings of the Review Panel will be informal, will not be subject to any rules of evidence, procedure or due process and will not be recorded. A decision of the Review Panel will be made by simple majority vote of the five voting members.

EXPUNGING VIOLATIONS

If, following a first violation, a student completes 12 consecutive months without a finding of a second violation, the student may make a written request to the Principal of the school attended by the student that the student's first violation be expunged from the student's record. The Principal, on considering the academic performance, attendance record, discipline record and school citizenship of the student and such other matters as the Principal deems relevant may so expunge the student's first violation. Only one violation may be so expunged.

Any first violation so expunged will not be counted in considering whether the student has committed a second, third or fourth violation.

A student's violations for acts committed while attending Gateway Middle School will be expunged from the student's record upon the student's graduation from Gateway Middle School. Any violation so expunged will not be counted in considering whether the student committed a second, third or fourth violation after the student was graduated from Gateway Middle School. If the privilege withdrawal period for an expunged violation extends beyond the student's graduation from Gateway Middle School, the expunging of a violation from the student's record on graduation from Gateway Middle School will not reduce the privilege withdrawal period for the expunged violation and, unless reduced by an appeal, the privilege withdrawal period will continue for its full term.

COMMUNITY REPRESENTATIVES

At the beginning of each school year, the Superintendent will name not less than five and not more than ten adult residents of the Maumee City School District who are not employees of the Maumee City School District to serve as Community Representatives. When a student makes an appeal of a finding of prohibited conduct or requests a reduction in a privilege withdrawal period, the Superintendent will select one of the Community Representatives to serve on the Appeal Panel or Review Panel convened to hear the student's appeal or request.

ACKNOWLEDGMENT

All participants in interscholastic athletics and extracurricular activities at Maumee High School and Gateway Middle School are expected to follow all of the rules and regulations as set forth by the Ohio High School Athletic Association as well as the Code of Conduct. Furthermore, participants are expected to follow all provisions of the Maumee City Schools' Code of Conduct as well as any additional rules as stated by activity advisors and team coaches. Please note that non-attendance pre-season informational meetings and/or failure to return the signed statement that indicates understanding of the Code of Conduct shall not excuse participants from abiding by its policies and procedures.



TRADITIONS

PURPLE AND GOLD

Purple conveys the idea of rank and authority. It denotes majesty and royalty. Our team fights under the color of purple in their conquests to win. It denotes the respect due our school faculty and classmates. Purple signifies the triumphs and leadership of Maumee High. Gold is a symbol of wealth. The wealth is knowledge and the golden friendships found here at Maumee High School are beyond the estimation of value. It's brilliant rays shine down through the years, illuminating the memories of high school, and reflecting the gold nuggets of understanding, guidance, and teachings which prepare us for life.

THE PANTHER

Symbolic of Maumee High School's spirit is the Panther, known for it's alertness, agility, and cleverness. Significantly, therefore; Maumee has chosen the panther, ever courageous in competition, as it's emblem. The agility of the panther has been well shown in our past record and is dependent upon the spark and vigor of the students of Maumee High School.

ALMA MATER

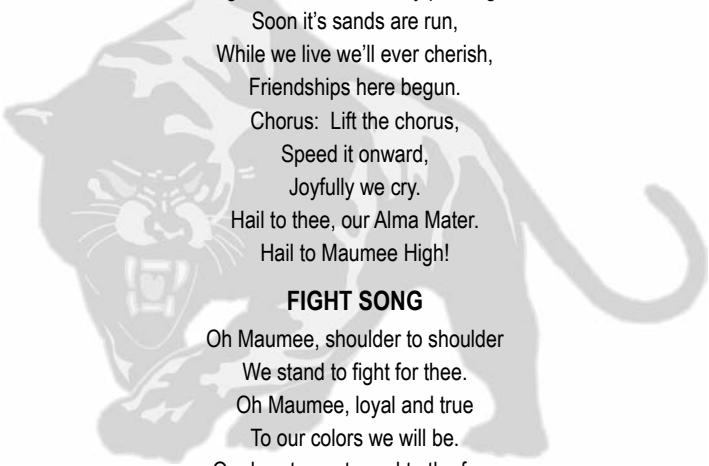

Hail to thee, O Maumee High School,
Loyalty we bring,
Tho' far we all may wander,
Praise to thee we sing.
High School life is swiftly passing,
Soon it's sands are run,
While we live we'll ever cherish,
Friendships here begun.
Chorus: Lift the chorus,
Speed it onward,
Joyfully we cry.
Hail to thee, our Alma Mater.
Hail to Maumee High!

FIGHT SONG

Oh Maumee, shoulder to shoulder
We stand to fight for thee.
Oh Maumee, loyal and true
To our colors we will be.
Our hearts are turned to the fray,
As our friends and foes shall always see.
We'll uphold thy fame, we will win the game.
Fighting on to victory.
With a Panther scream we will back our team,
And we'll win for old Maumee!